



## General warnings

This manual has been prepared for use by qualified persons and therefore not by trainees or “do it yourselfers”.

The persons how assembly, disassembly, maintain or put the door system into operation need to careful read, understand and follow this manual. To avoid severe personal injury, carefully read and observe all indications and warnings in this manual.

- This manual describes the assembly, disassembly and maintenance of your Residential Door System; this may be supplemented by other manuals, for instance the spring break device manual, cable break device and operator manual (if applicable.)
- The Residential Door System has been designed in accordance with the latest European standards; however you have to check yourself whether this standard corresponds with the local national standard.
- All measurements are in millimeters unless otherwise specified.
- After installation ensure that the CE marking label has been completed and attached.
- Keep this manual in a safe place, near to the Residential door.
- Subject to technical changes, without written notice.

## Safety requirements for assembly and first use

- This Residential Door System may only be mounted, connected and put into operation and maintained by qualified persons.
- Make sure that the power is switched off and remains switched off while electrical work is carried out!
- Never bridge safety devices!
- Adding or leaving out parts can affect the door operation in a negative way and therefore the safety of the installed sectional door. This is therefore strongly discouraged!
- Some parts can contain sharp edges: use protective gloves. • All references to the door/component handing within this manual is always as viewed from inside looking out.
- Never use the Residential Door System in case of a visual damage, especially cables and safety devices.
- When performing assembly/maintenance, always wear at least gloves and safety boots and during drilling/cutting wear safety goggles!
- Make sure that you can always perform your work in a stable environment.
- Secure the assembly/maintenance site with safety ribbon to keep others at a distance.
- Maintenance must only be performed by a qualified installation company and/or qualified persons.
- Make sure there is enough light.
- Only use appropriate tools, especially when tensioning the torsion springs.



## Fixing material to the construction

The necessary fixings to ensure the Residential Door System to the building and/or ceiling, are not included! It is the responsibility of the installation company to make sure that the building structure is safe/strong enough, to accept the door and its fixings. The installer is also responsible for using the correct fixing materials on the right foundation (stone, concrete, steel, wood). In the image section there will be therefore no specification included.

Doorweight\* for roofload: 510 N/m<sup>2</sup>

Using doorblades between 7-14 kg/m<sup>2</sup>



## System Overview and build in requirements

See *Residential Track Systems* document for system drawings, build in requirements and required free running space of the residential door.

Big differences in temperature between the inside and outside can cause deflection in the panel sections (bi-metal effect). In particular dark colored panels are susceptible to this problem and should be avoided. Care should be taken during manual handling as there is a big risk of damage.



# A1- A9

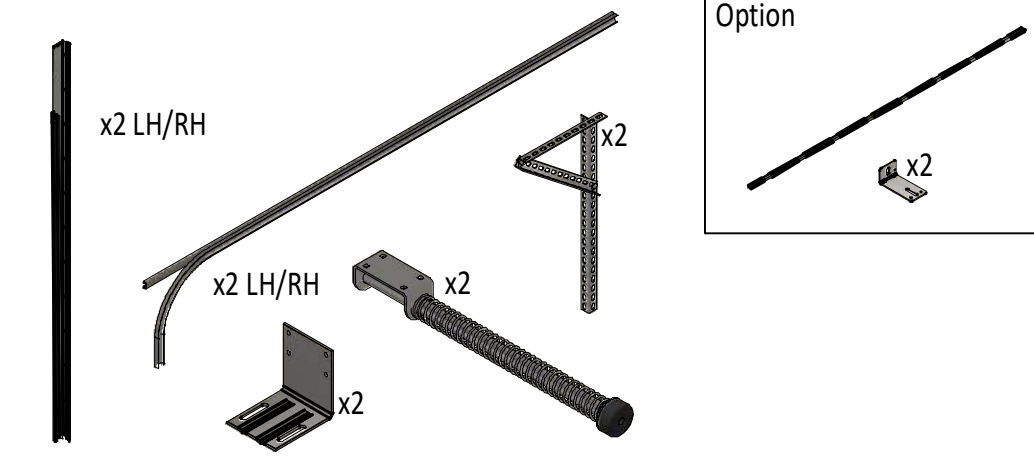
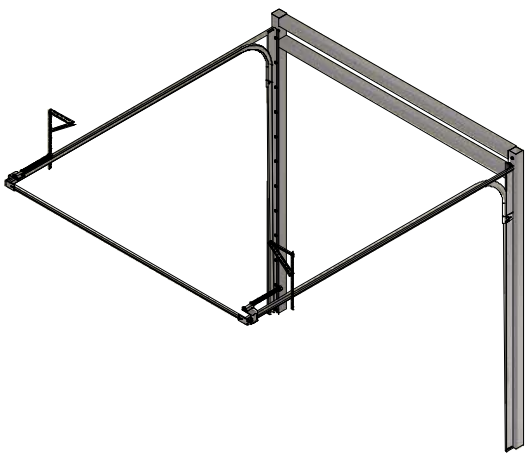

# B1- B5

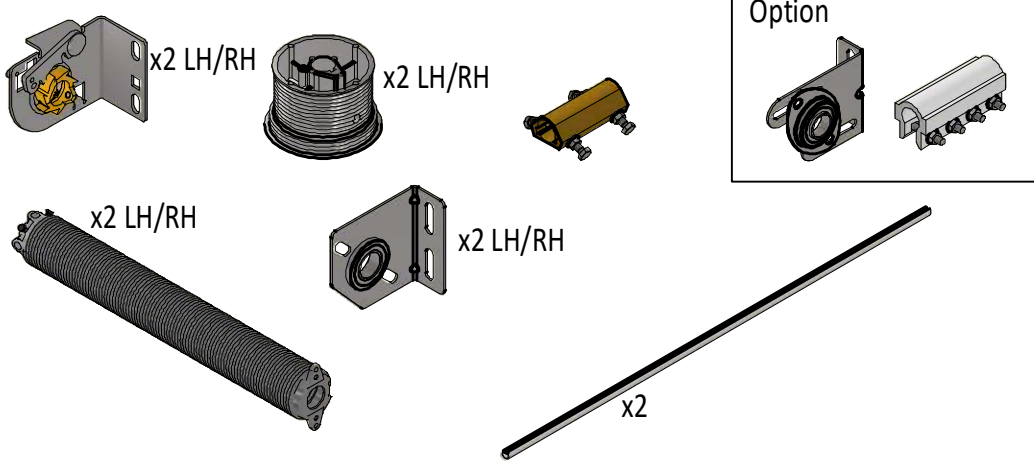
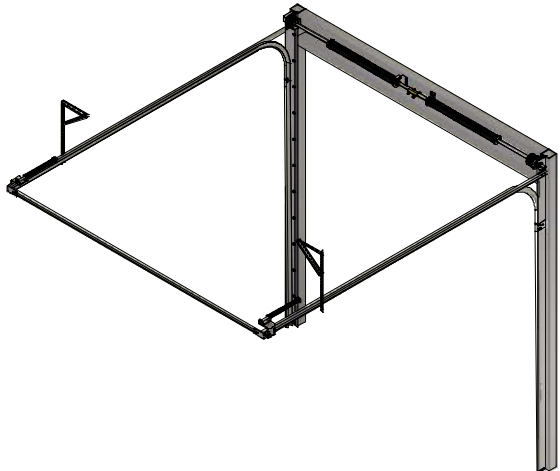

# C1- C11

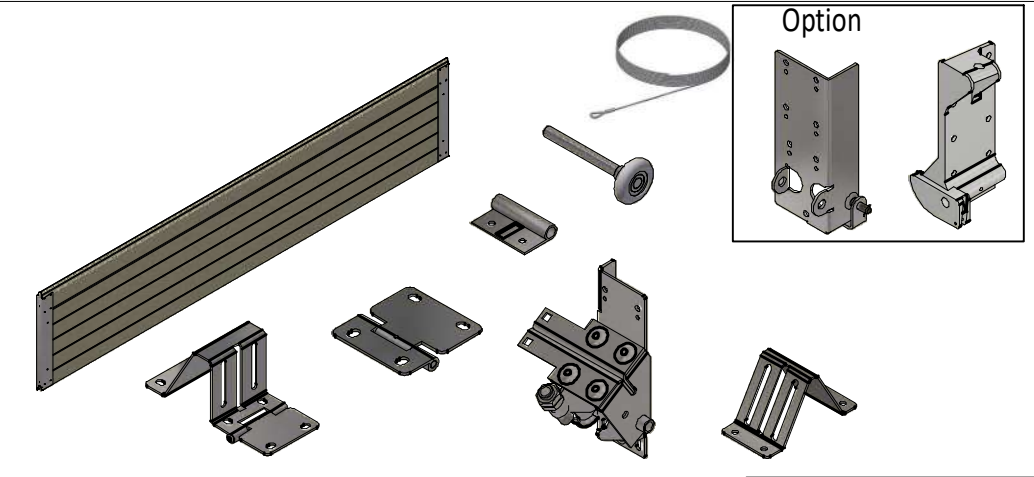
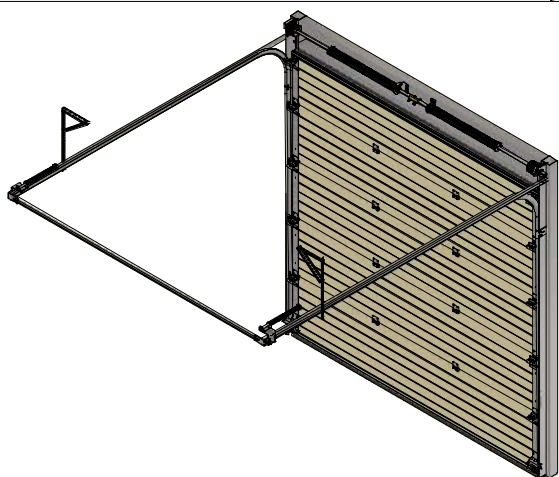

# C2.1- C2.4

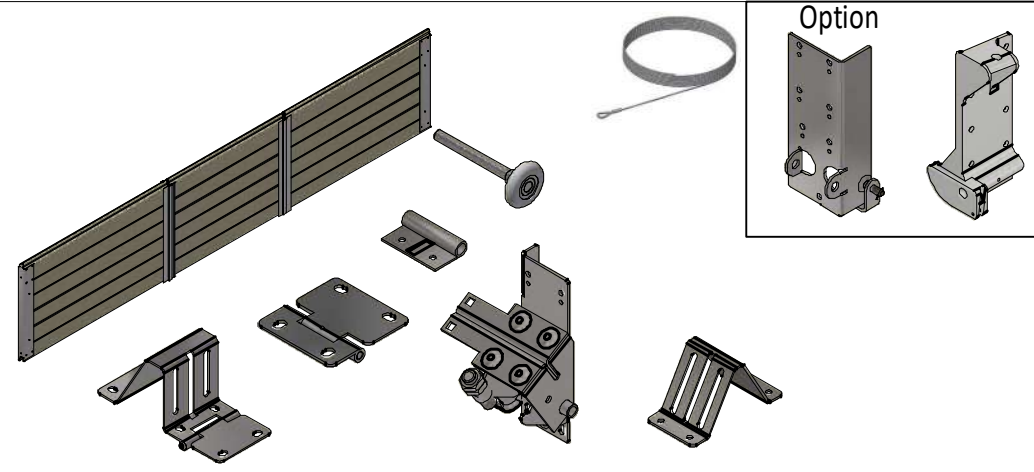
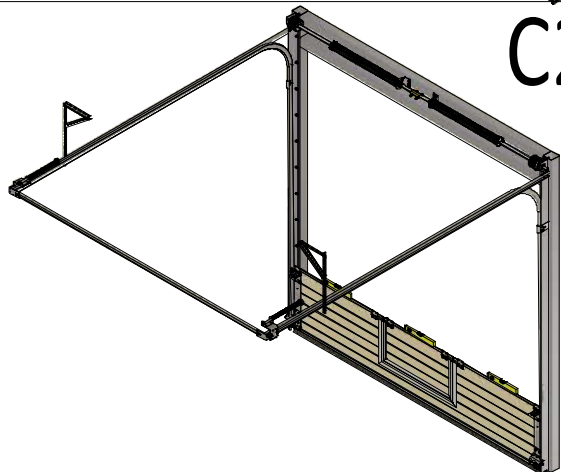

# D1- D8

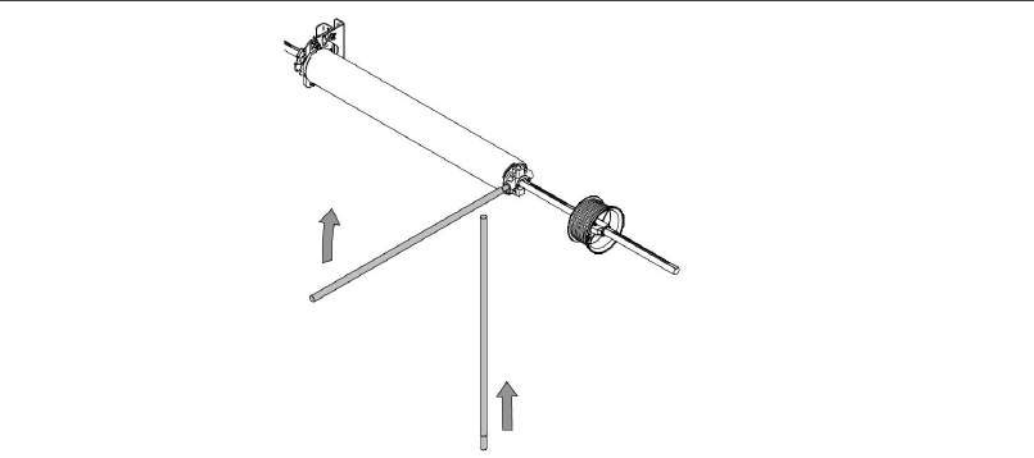
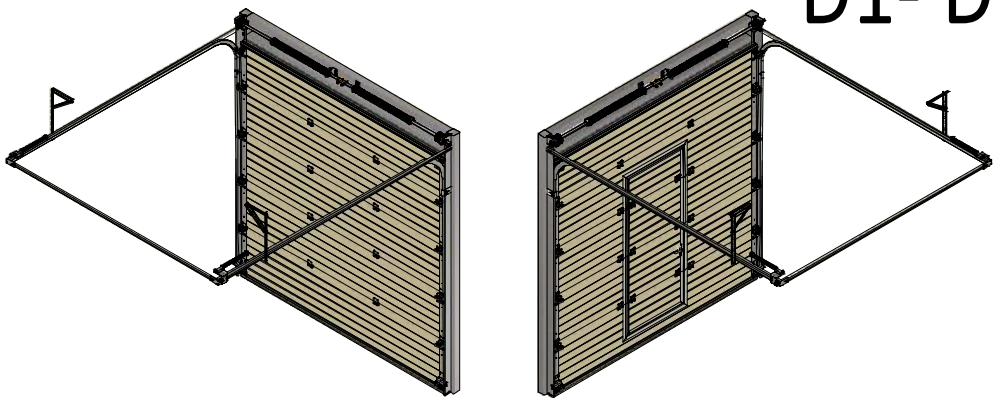

# E1- E2

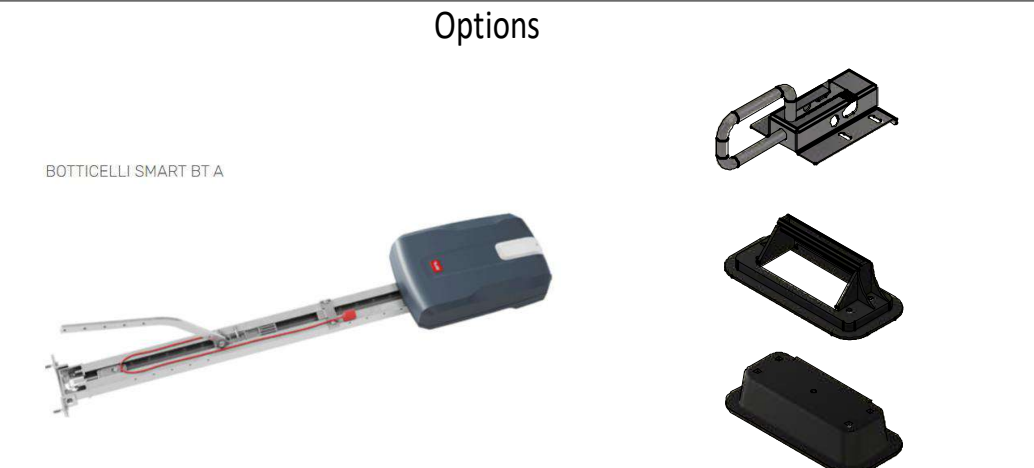
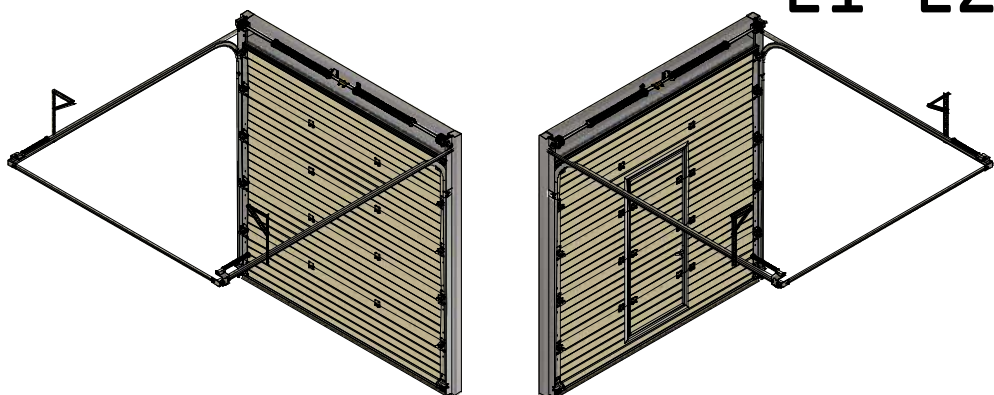

**Riga Door Systems**  
we open the world

Malas, Vetras, Marupe LV-2167, Riga district, Latvia; web: www.rigadoors.lv

Designed by

VPA

Sheet Format

A3

Date

2023-12-08

Installation manual. RS 350

RDS 1000

Rev.

2

Sheet

3 / 38

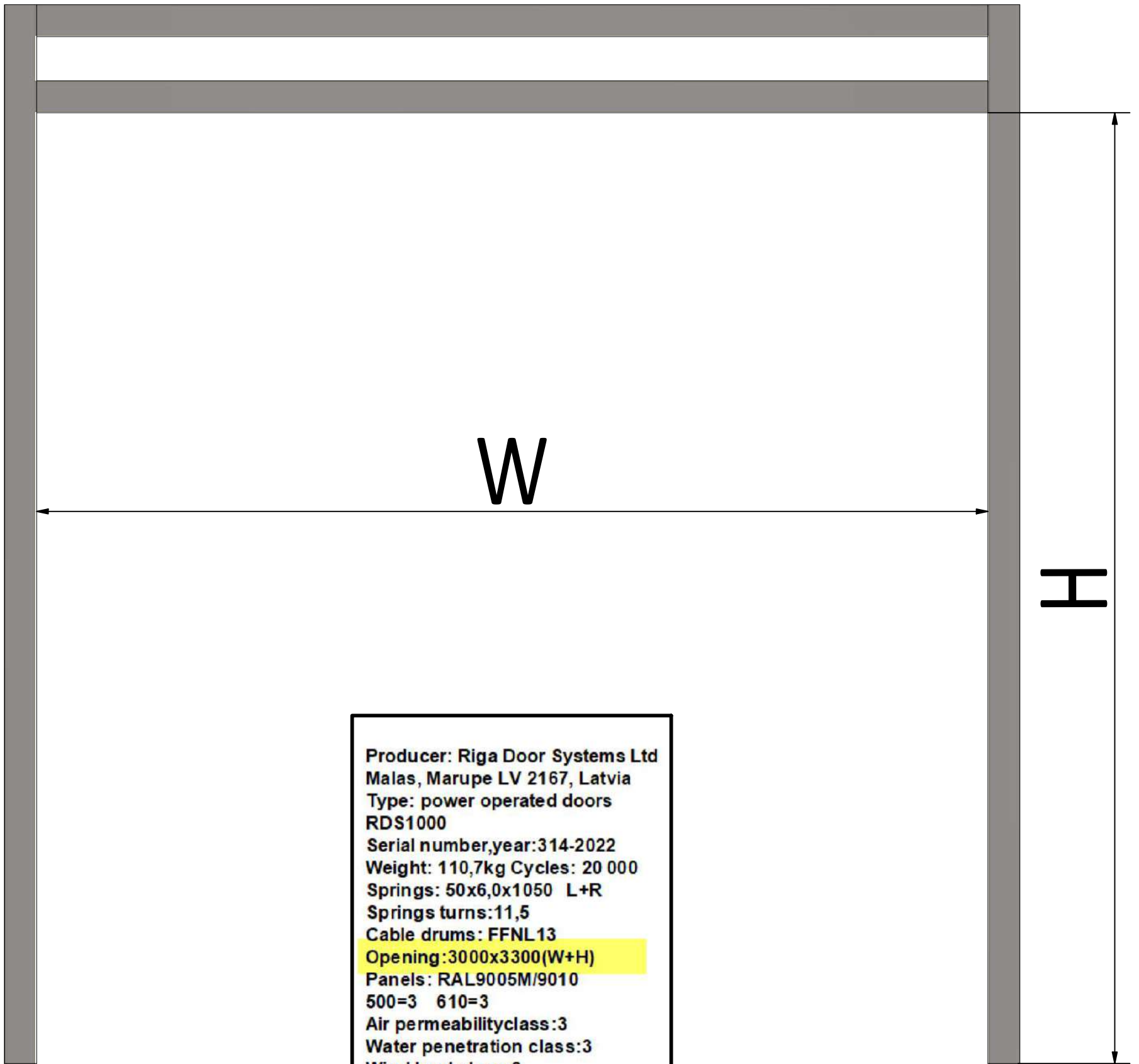

Producer: Riga Door Systems Ltd  
 Malas, Marupe LV 2167, Latvia  
 Type: power operated doors  
 RDS1000  
 Serial number, year: 314-2022  
 Weight: 110,7kg Cycles: 20 000  
 Springs: 50x6,0x1050 L+R  
 Springs turns: 11,5  
 Cable drums: FFNL13  
 Opening: 3000x3300(W+H)  
 Panels: RAL9005M/9010  
 500=3 610=3  
 Air permeability class: 3  
 Water penetration class: 3  
 Wind load class: 3  
 Thermal resistance W/(m<sup>2</sup>K): 1,4  
 EN13241:2003+A2:2016

**CE**

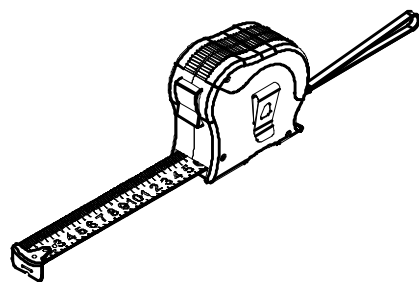
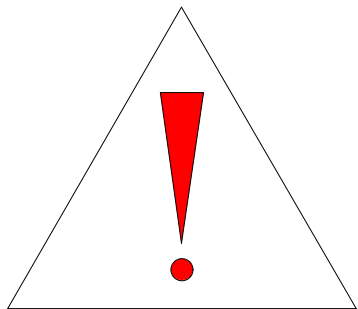

W=W

H=H



Designed by	VPA	Sheet Format	A3	Date	2023-12-08	Installation manual. RS 350		
						RDS 1000	Rev. 2	Sheet 4 / 38

A2

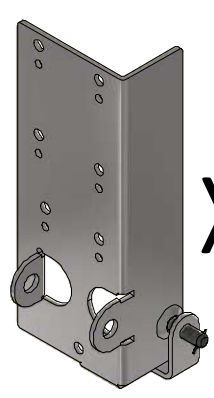
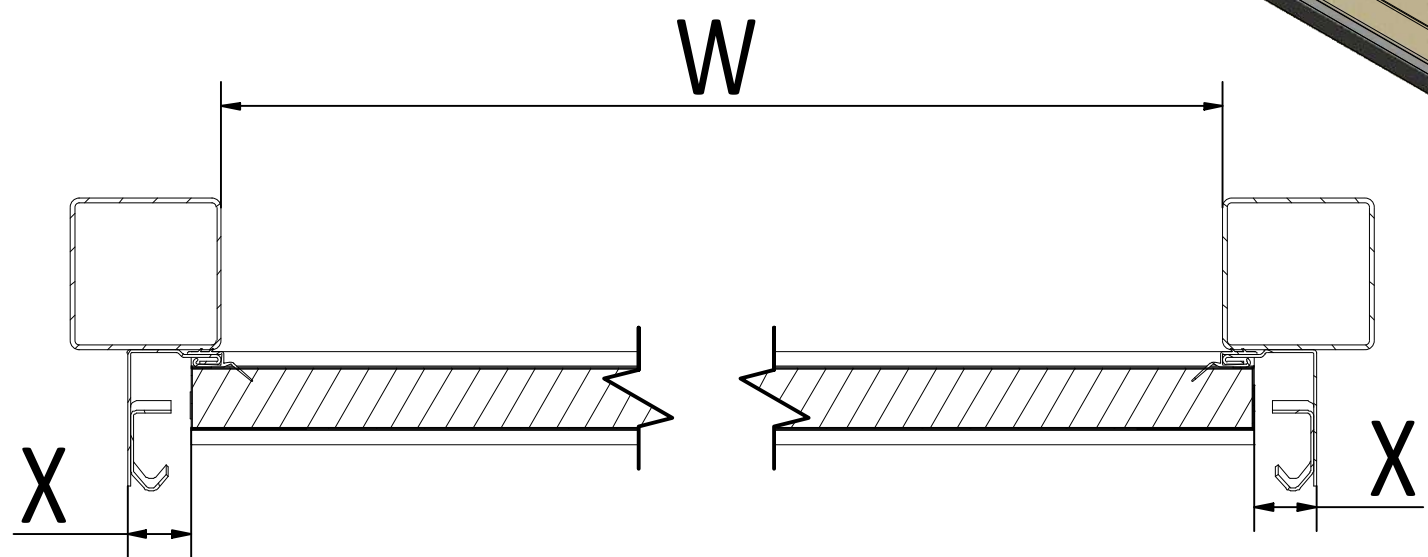
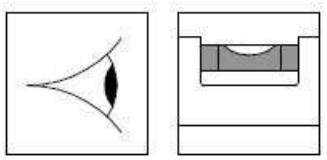

X= 35mm

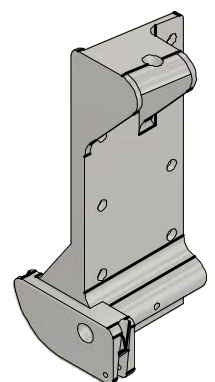

X= 40mm

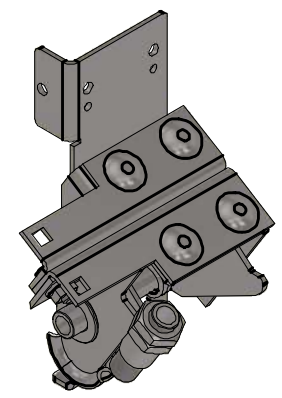

X= 50mm



**Riga Door Systems**  
we open the world

Malas, Vetras, Marupe LV-2167, Riga district, Latvia; web: [www.rigadoors.lv](http://www.rigadoors.lv)

Designed by	VPA	Sheet Format	A3	Date	2023-12-08	Installation manual. RS 350		
						RDS 1000	Rev. 2	Sheet 5 / 38

A3

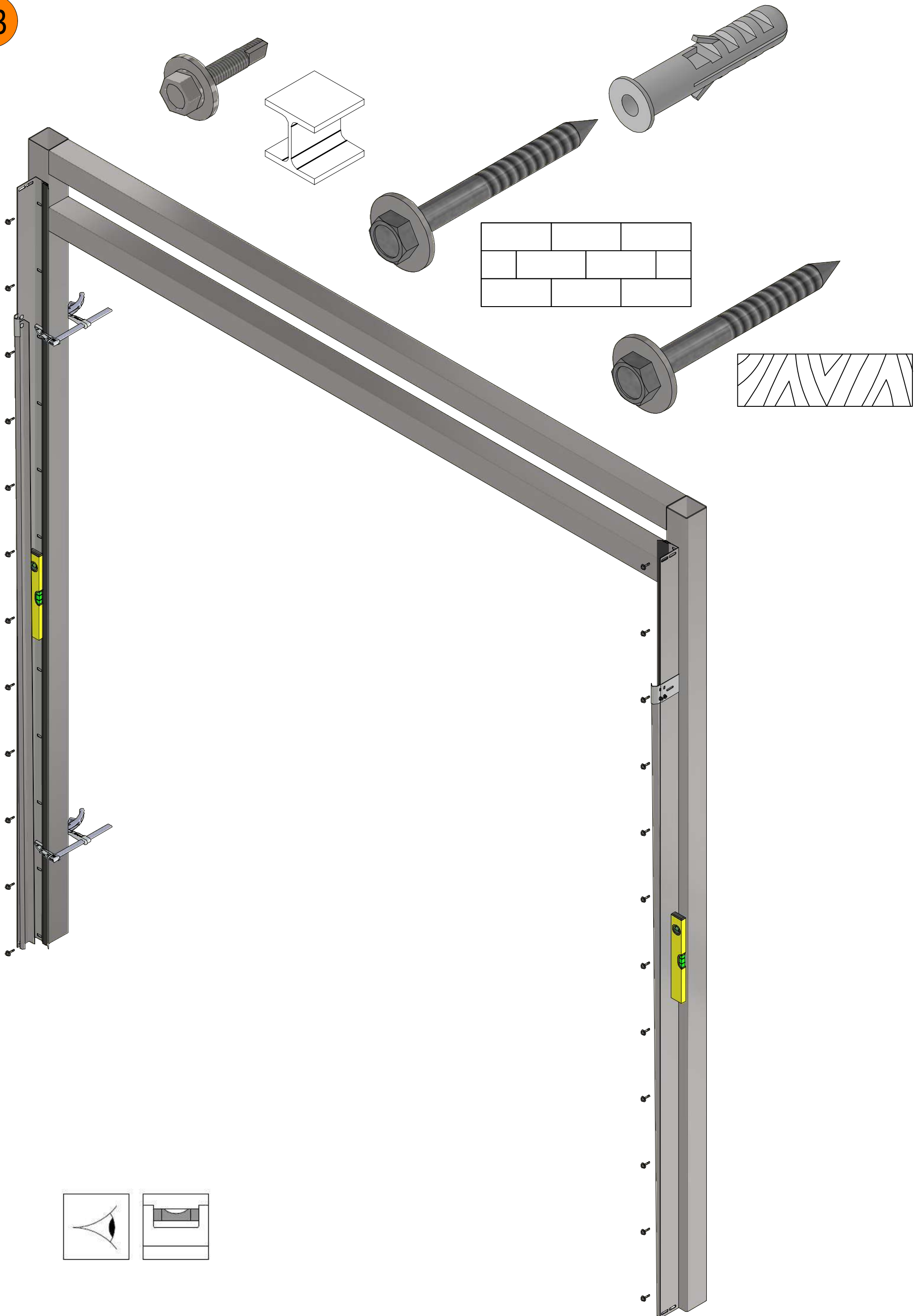

**Riga Door Systems**  
we open the world

Malas, Vetras, Marupe LV-2167, Riga district, Latvia; web: [www.rigadoors.lv](http://www.rigadoors.lv)

Designed by	VPA	Sheet Format	A3	Date	2023-12-08	Installation manual. RS 350		
						RDS 1000	Rev. 2	Sheet 6 / 38

A4

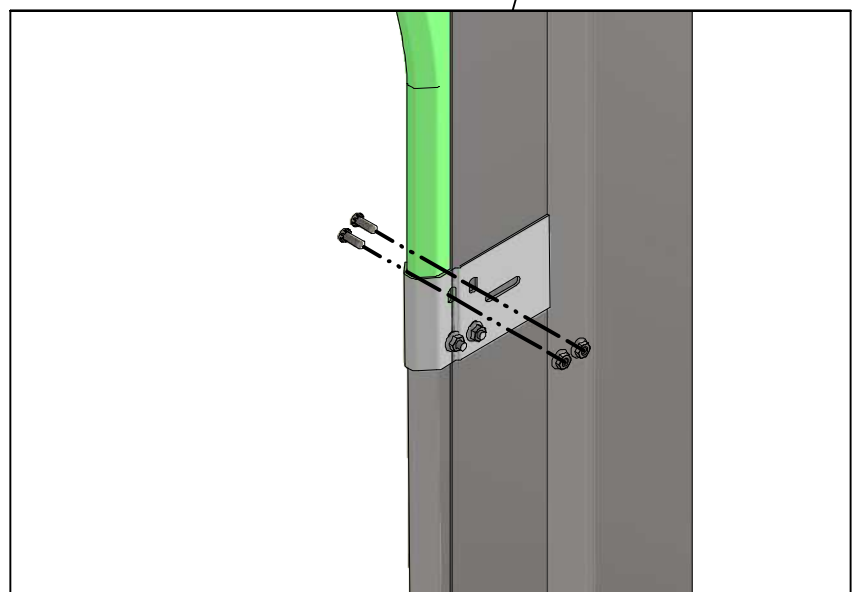
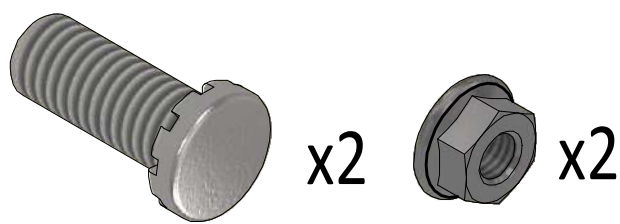
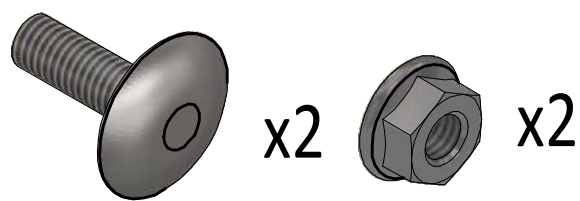
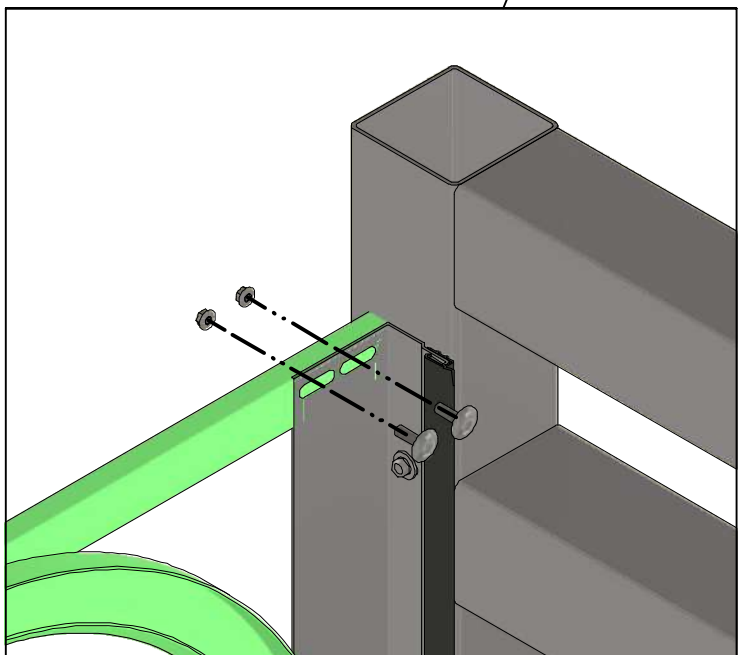
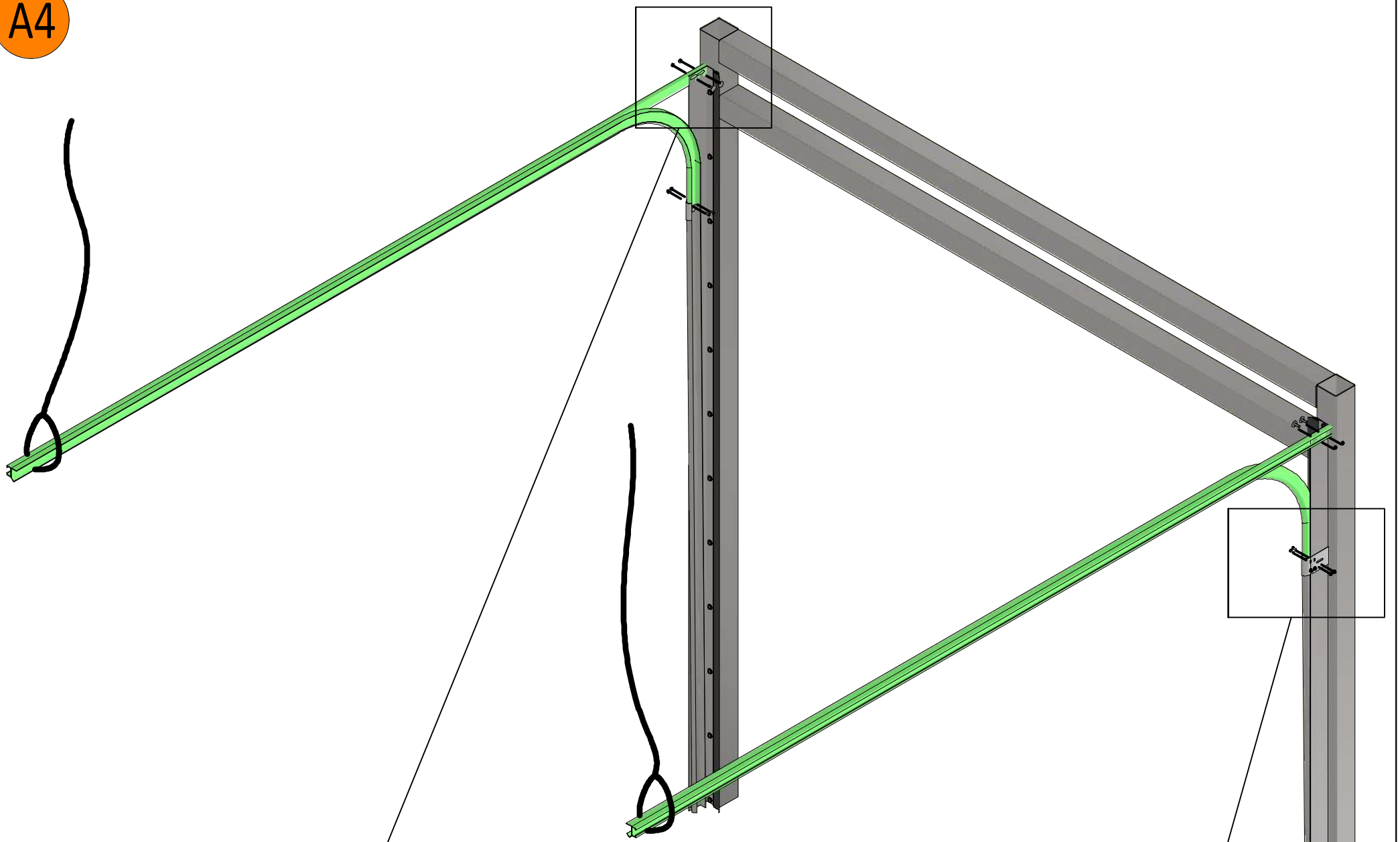

**Riga Door Systems**  
we open the world

Malas, Vetras, Marupe LV-2167, Riga district, Latvia; web: [www.rigadoors.lv](http://www.rigadoors.lv)

Designed by

VPA

Sheet Format

A3

Date

2023-12-08

Installation manual. RS 350

RDS 1000

Rev.

2

Sheet

7 / 38





# Optionally

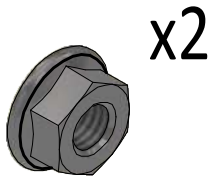
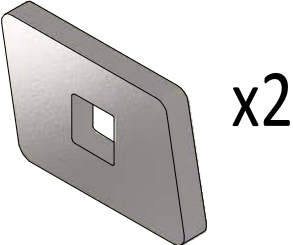
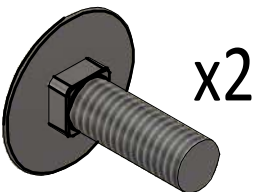
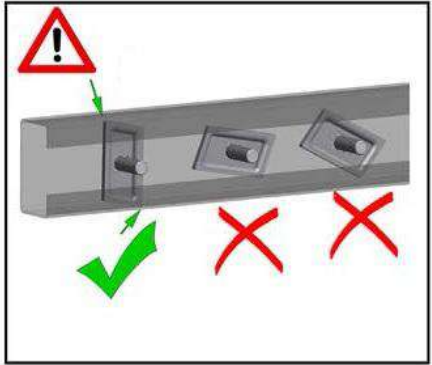
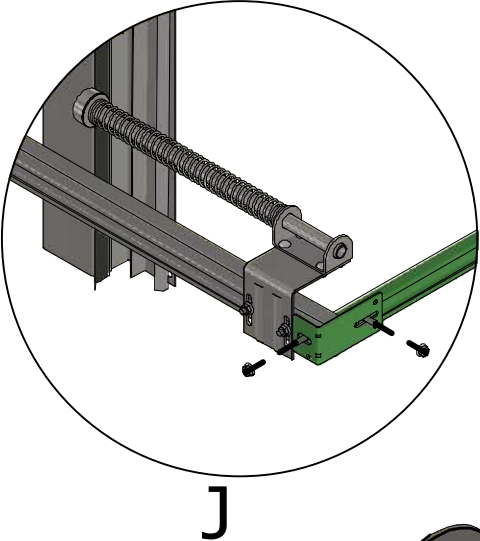
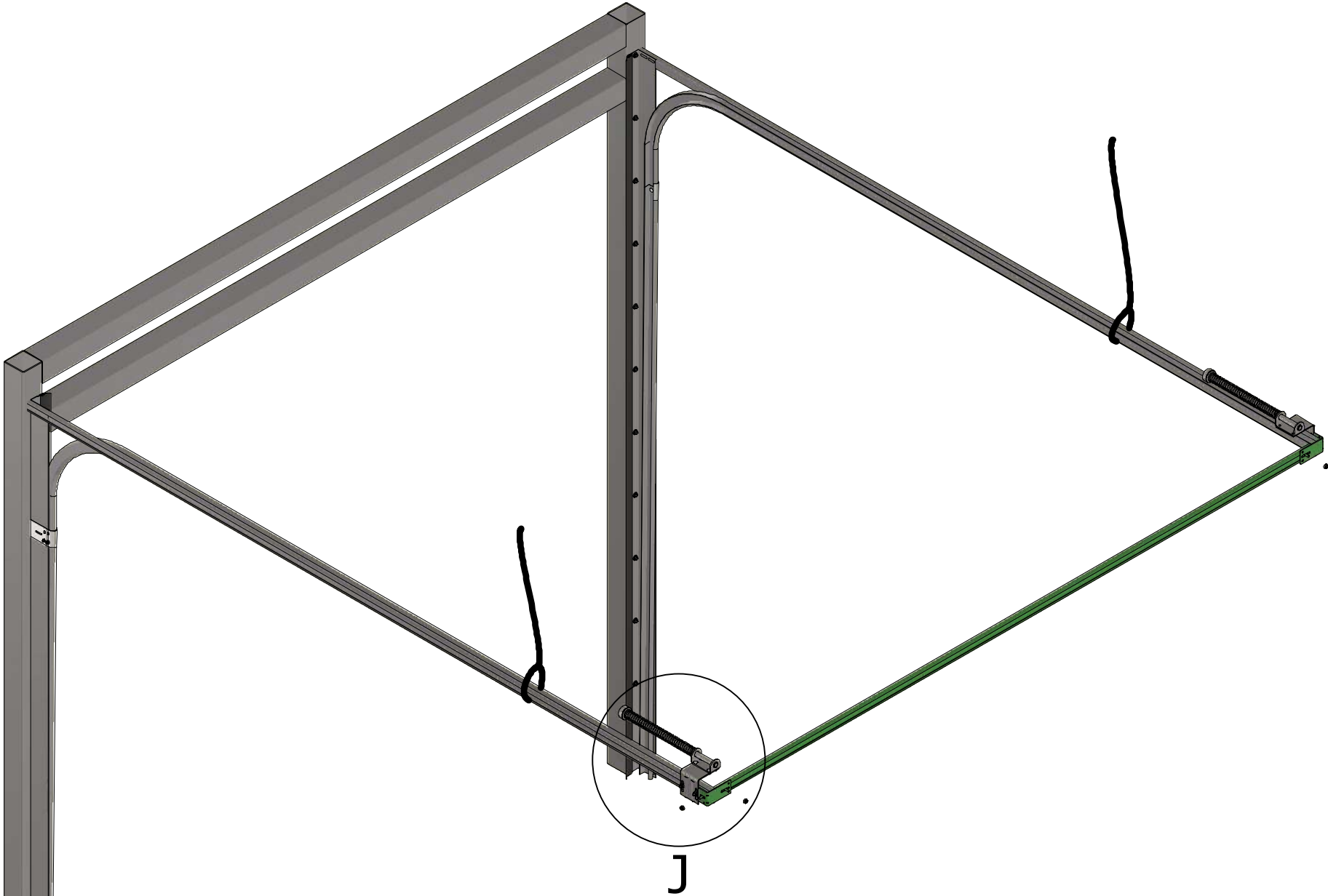

Designed by	VPA	Sheet Format	A3	Date	2023-12-08	Installation manual. RS 350		
						RDS 1000	Rev. 2	Sheet 9 / 38



A8

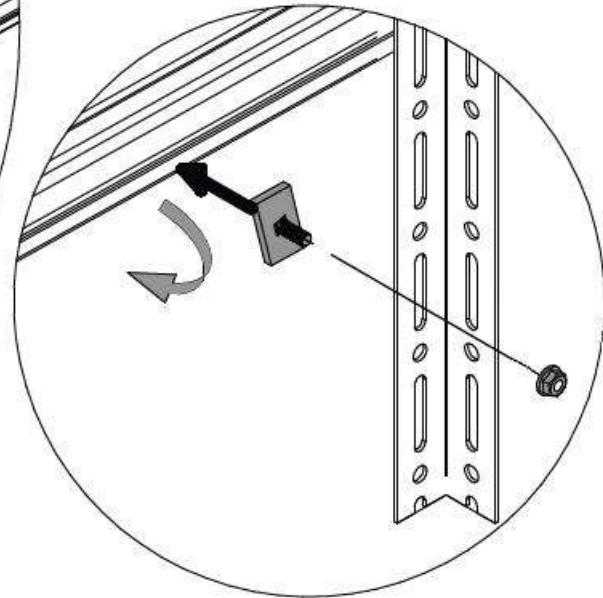
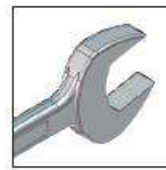
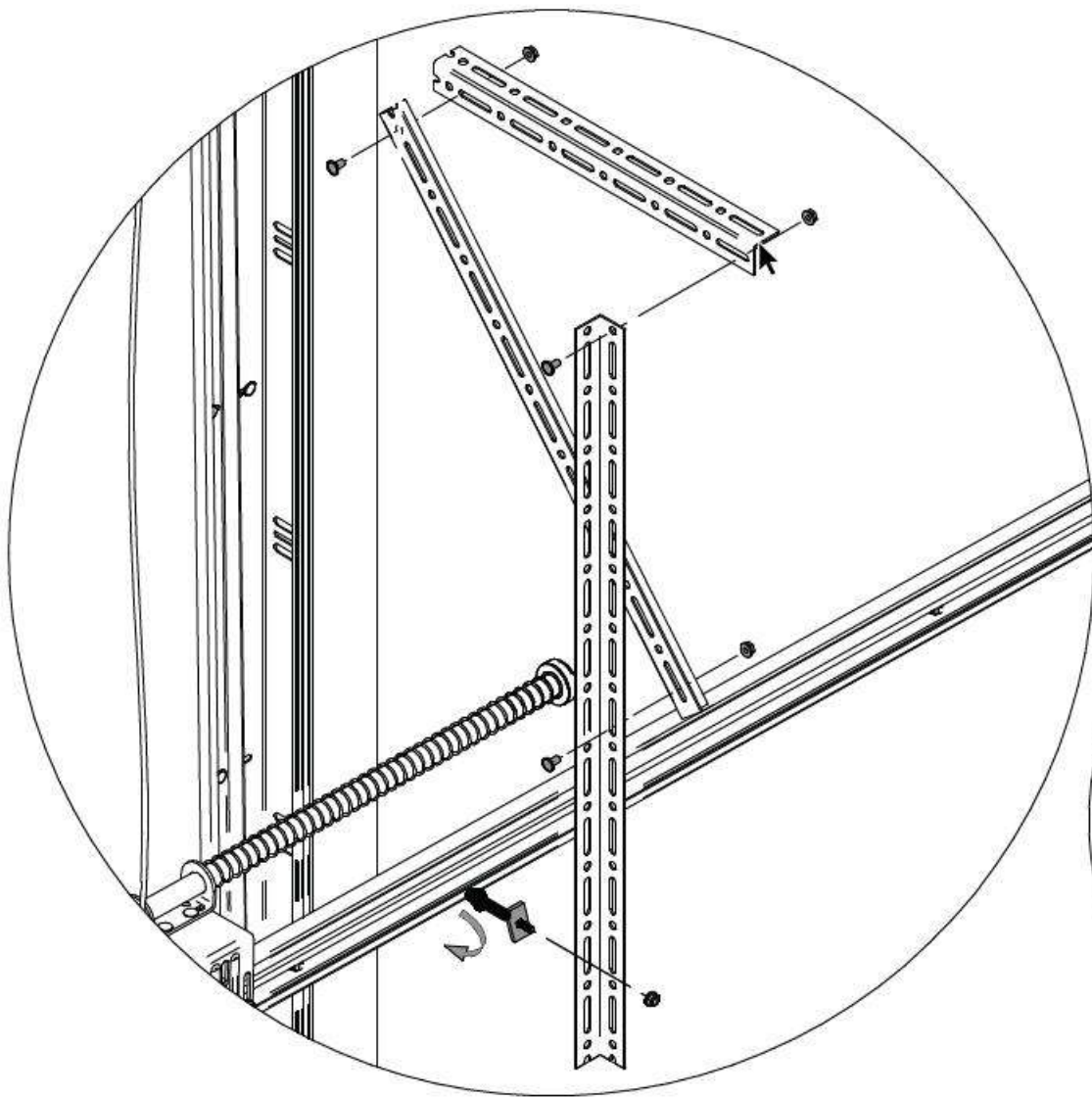
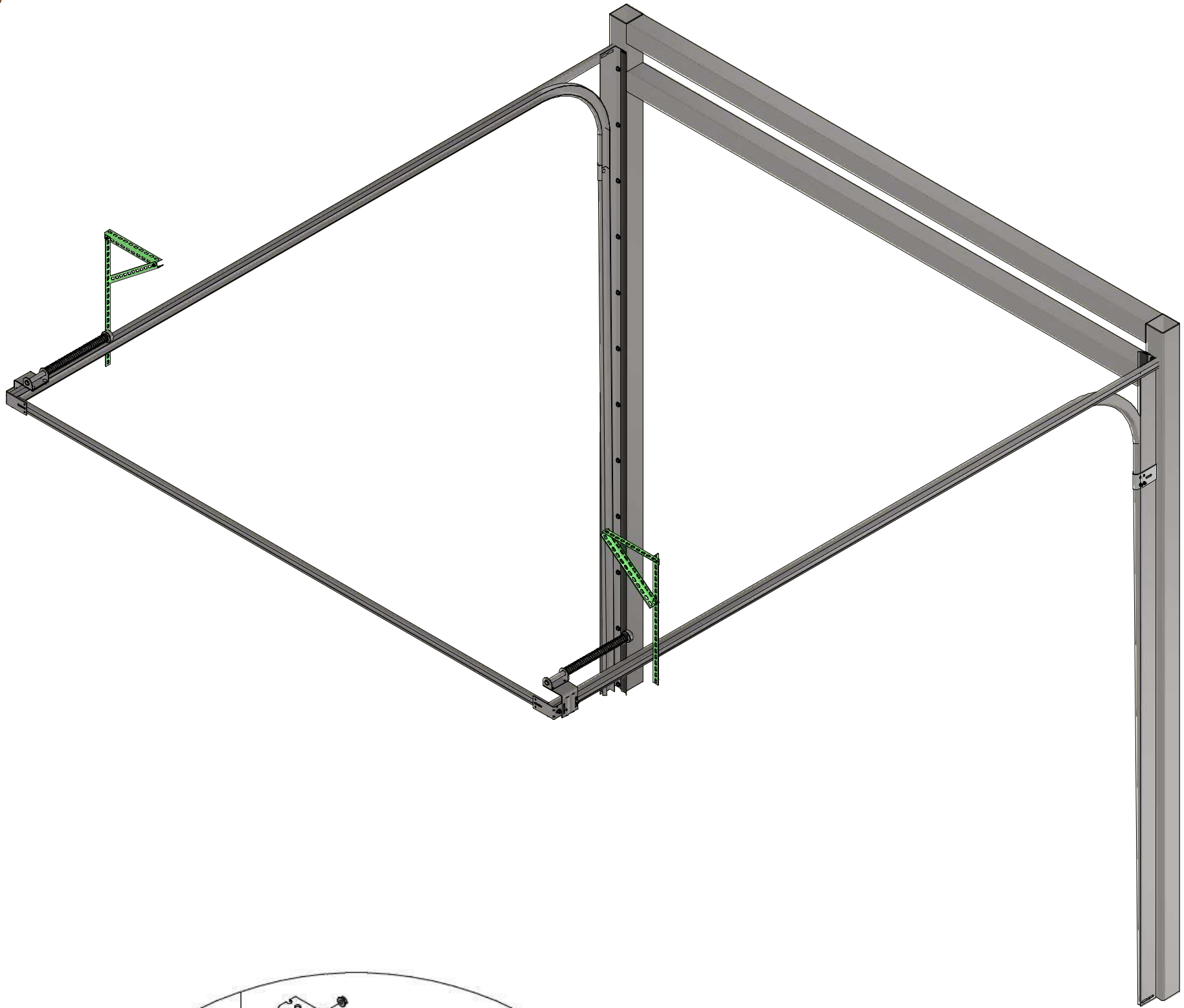

**Riga Door Systems**  
we open the world

Malas, Vetras, Marupe LV-2167, Riga district, Latvia; web: [www.rigadoors.lv](http://www.rigadoors.lv)

Designed by

VPA

Sheet Format

A3

Date

2023-12-08

Installation manual. RS 350

RDS 1000

Rev.

2

Sheet

11 / 38

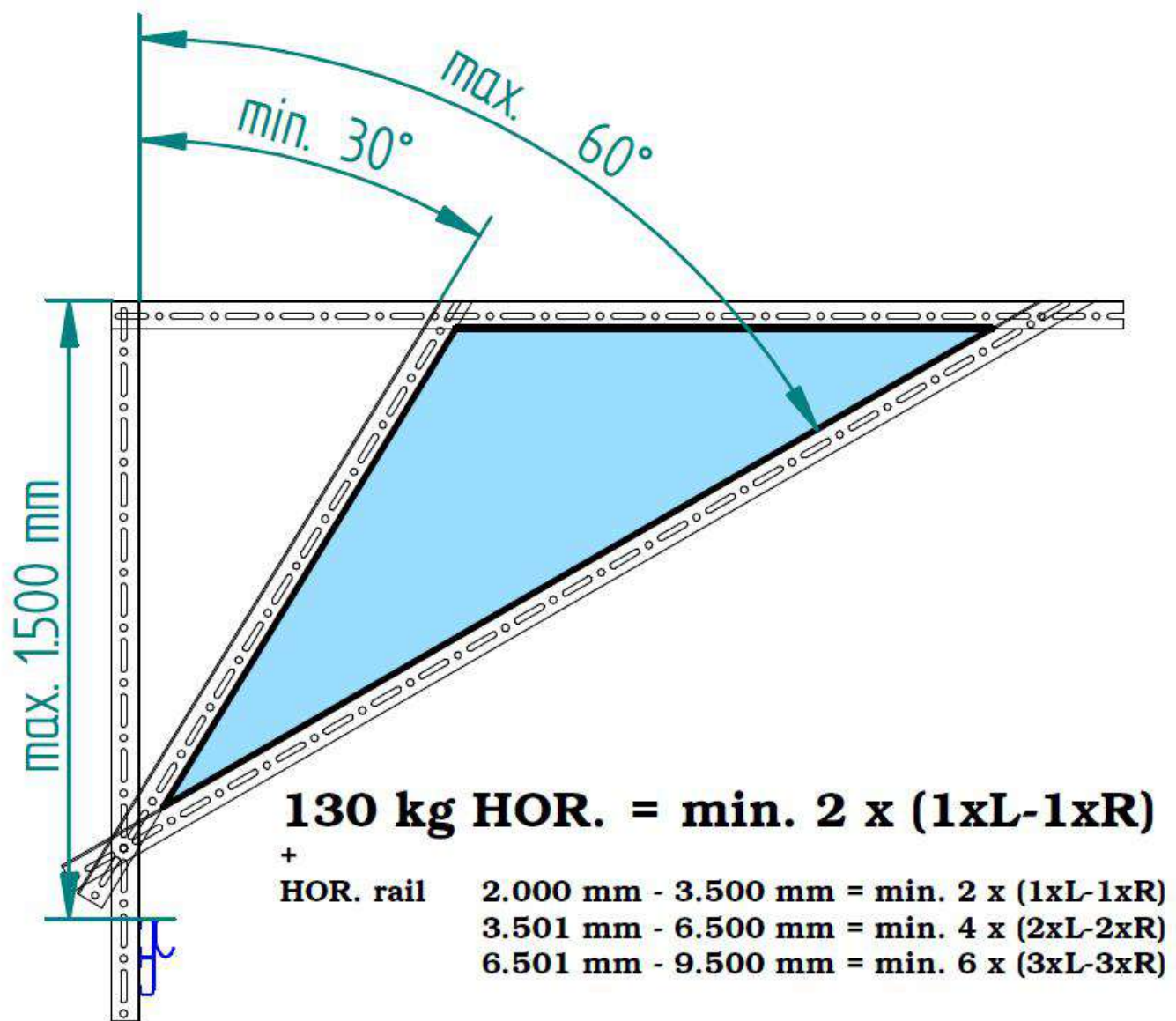
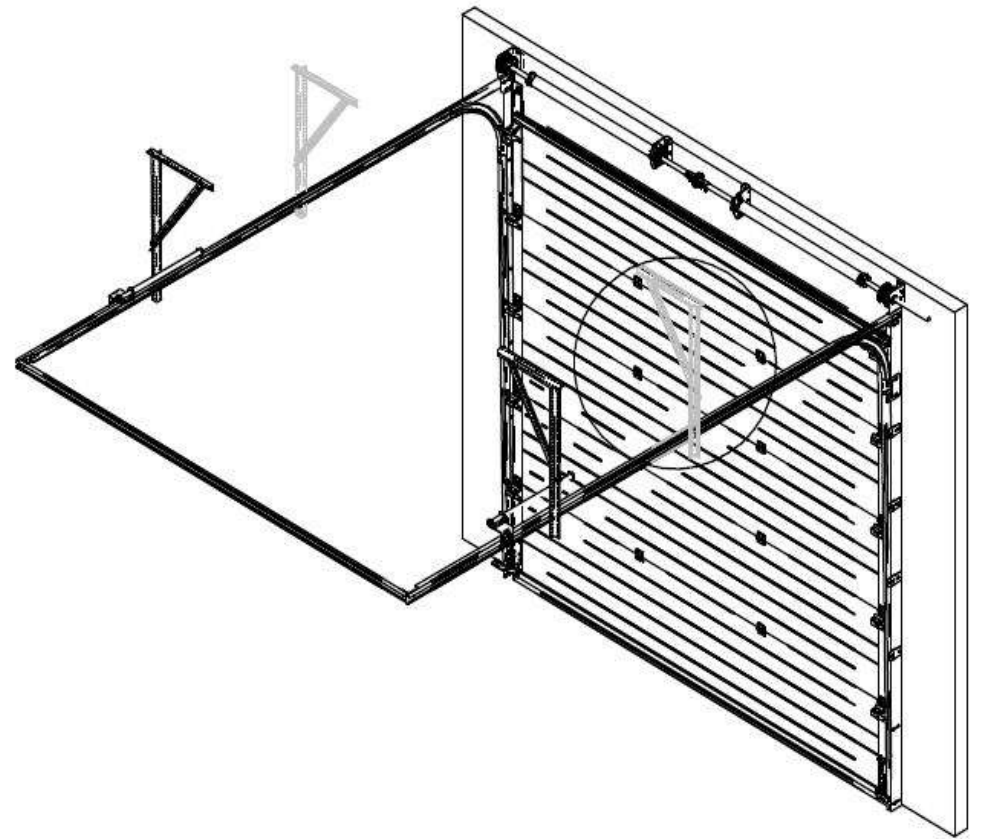
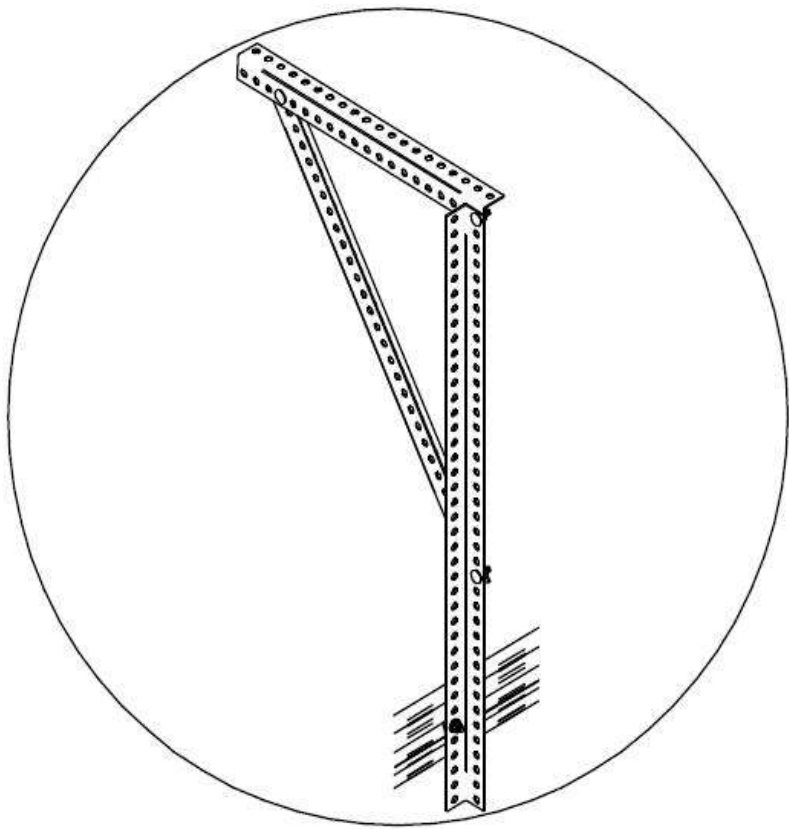

Designed by	VPA	Sheet Format	A3	Date	2023-12-08	Installation manual. RS 350	Rev.	Sheet
						RDS 1000	2	12 / 38

B1

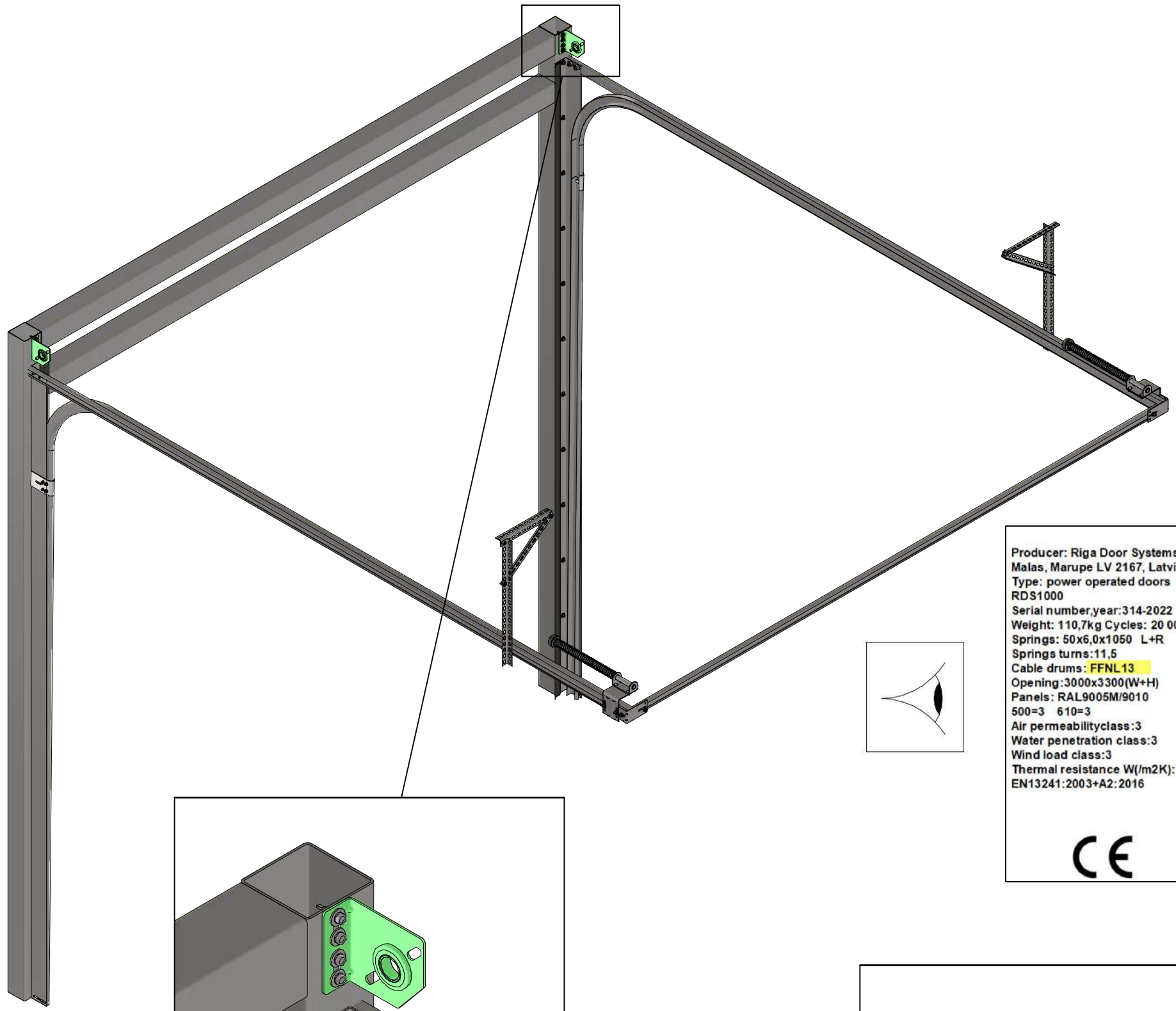

Producer: Riga Door Systems Ltd  
 Malas, Marupe LV 2167, Latvia  
 Type: power operated doors  
 RDS1000  
 Serial number, year: 314-2022  
 Weight: 110,7kg Cycles: 20 000  
 Springs: 50x6,0x1050 L+R  
 Springs turns: 11,5  
 Cable drums: FFNL13  
 Opening: 3000x3300(W+H)  
 Panels: RAL9005M/9010  
 500=3 610=3  
 Air permeability class: 3  
 Water penetration class: 3  
 Wind load class: 3  
 Thermal resistance W/(m2K): 1,4  
 EN13241:2003+A2:2016

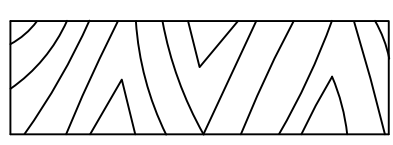
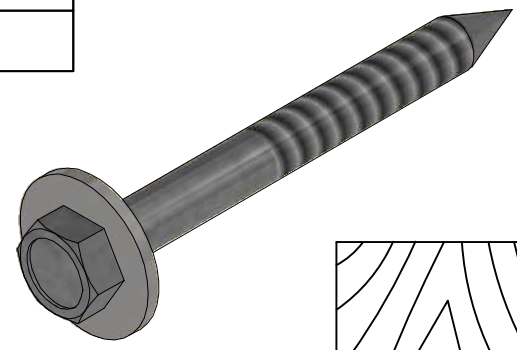
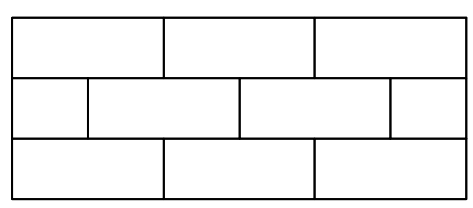
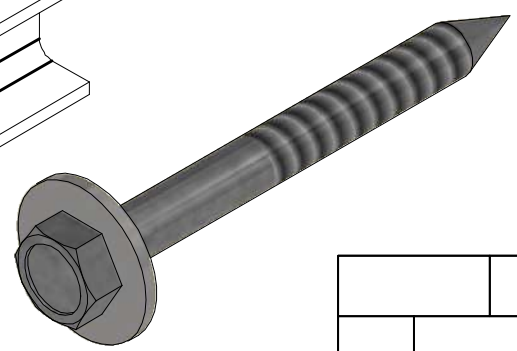
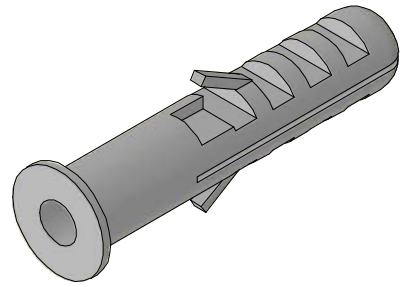
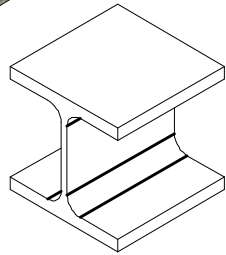
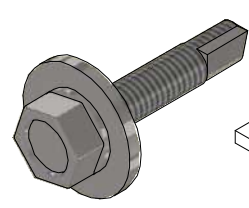
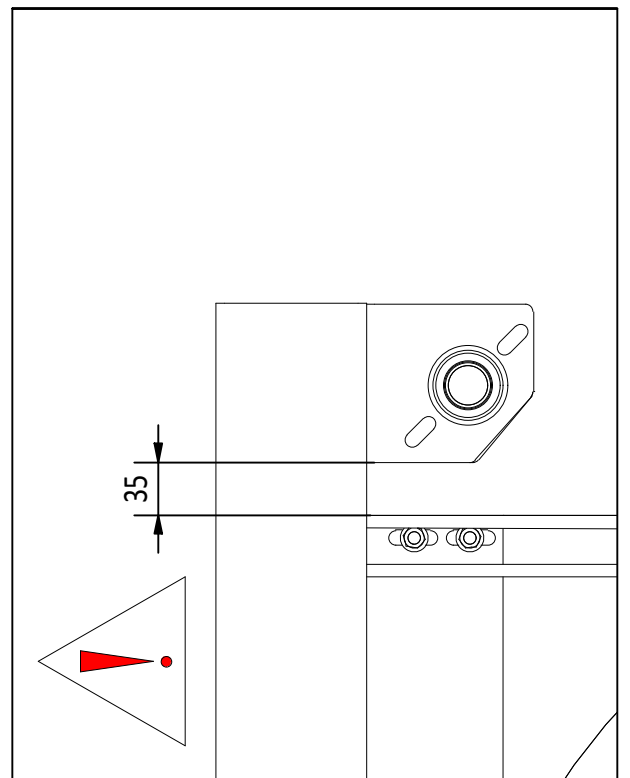
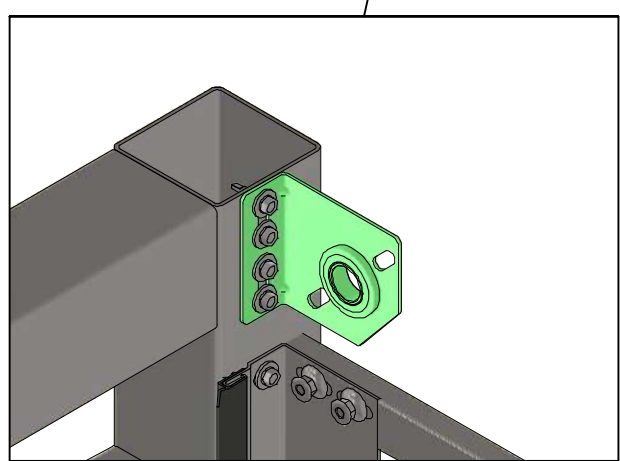
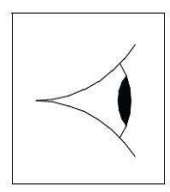

**Riga Door Systems**  
we open the world

Malas, Vetras, Marupe LV-2167, Riga district, Latvia; web: www.rigadoors.lv

Designed by	VPA	Sheet Format	A3	Date	2023-12-08	Installation manual. RS 350		
						RDS 1000	Rev. 2	Sheet 13 / 38



B4

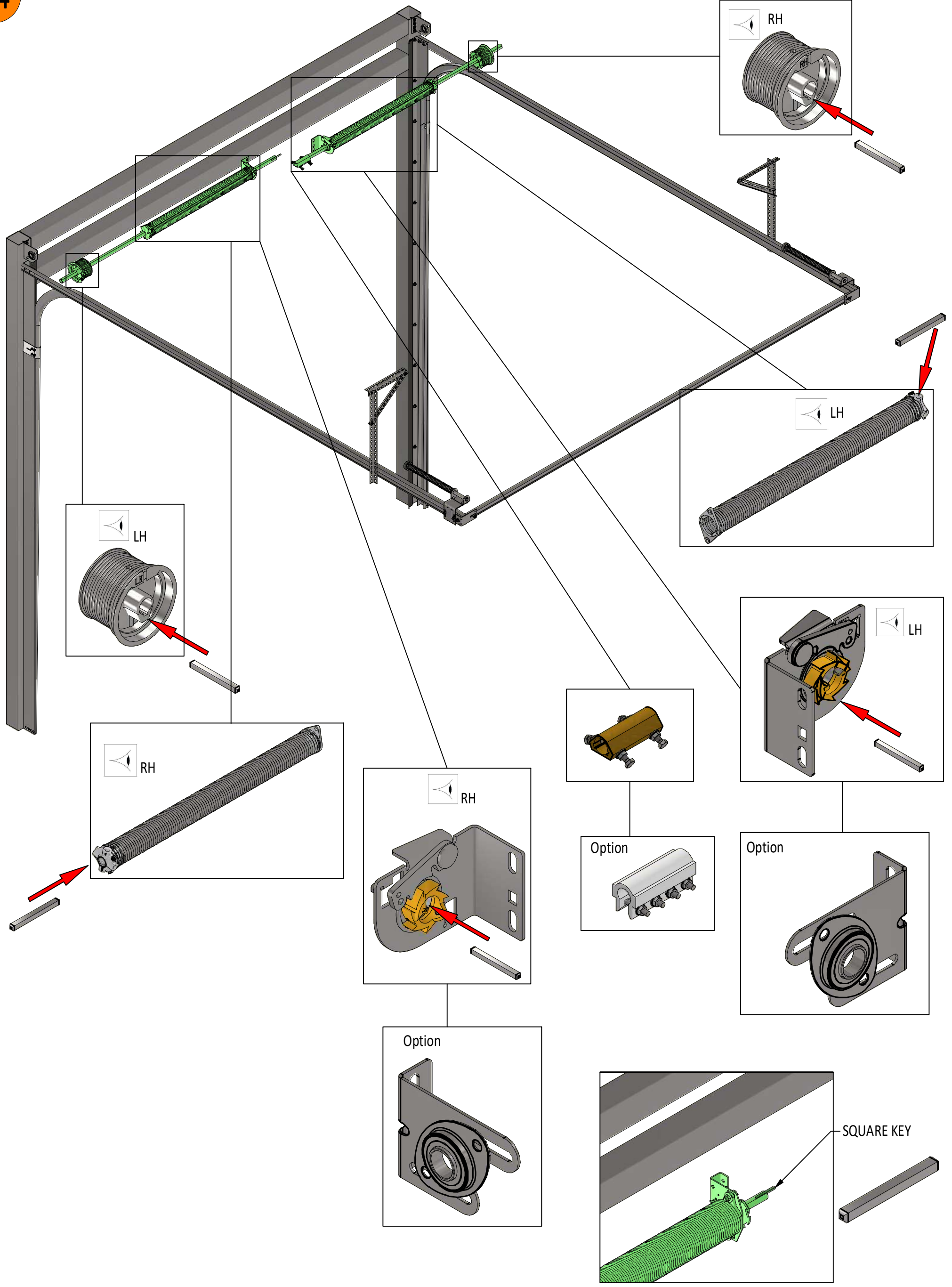

**Riga Door Systems**  
we open the world

Malas, Vetras, Marupe LV-2167, Riga district, Latvia; web: www.rigadoors.lv

Designed by VPA Sheet Format A3 Date 2023-12-08

Installation manual. RS 350

RDS 1000

Rev. 2 Sheet 15 / 38



B5

# OPTION - Single shaft

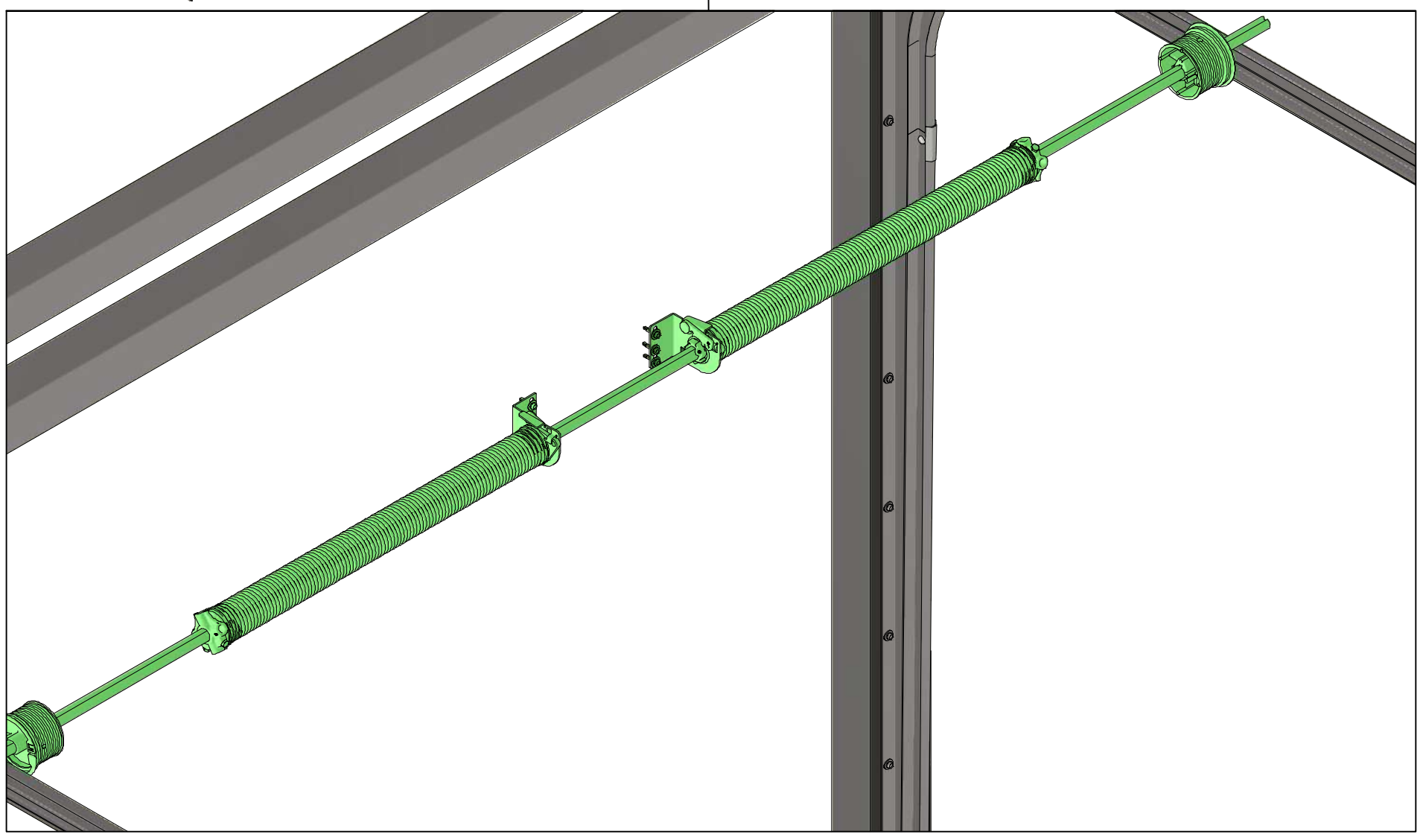
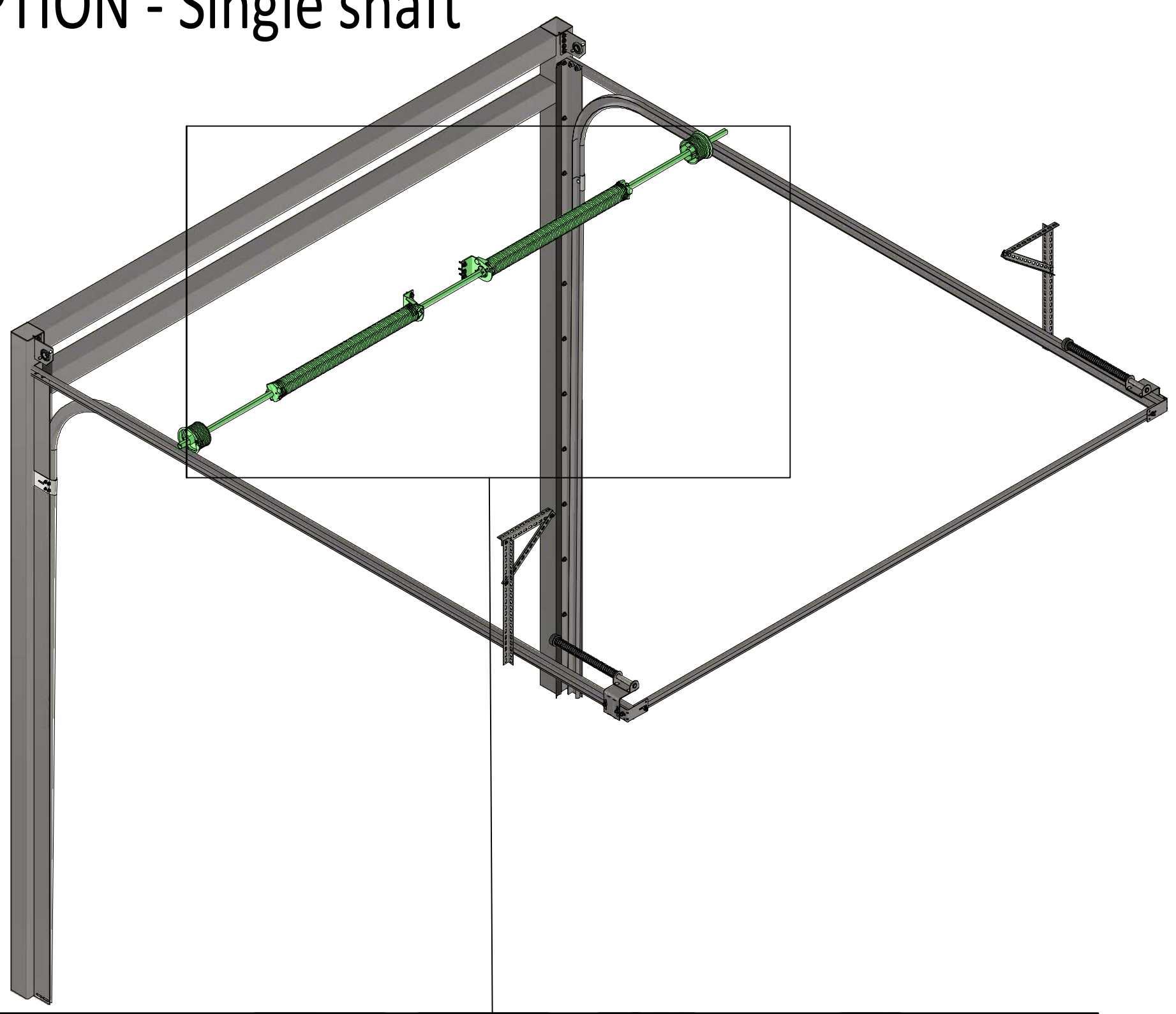

**Riga Door Systems**  
we open the world

Malas, Vetras, Marupe LV-2167, Riga district, Latvia; web: [www.rigadoors.lv](http://www.rigadoors.lv)

Designed by	VPA	Sheet Format	A3	Date	2023-12-08	Installation manual. RS 350		
						RDS 1000	Rev. 2	Sheet 16 / 38

C1

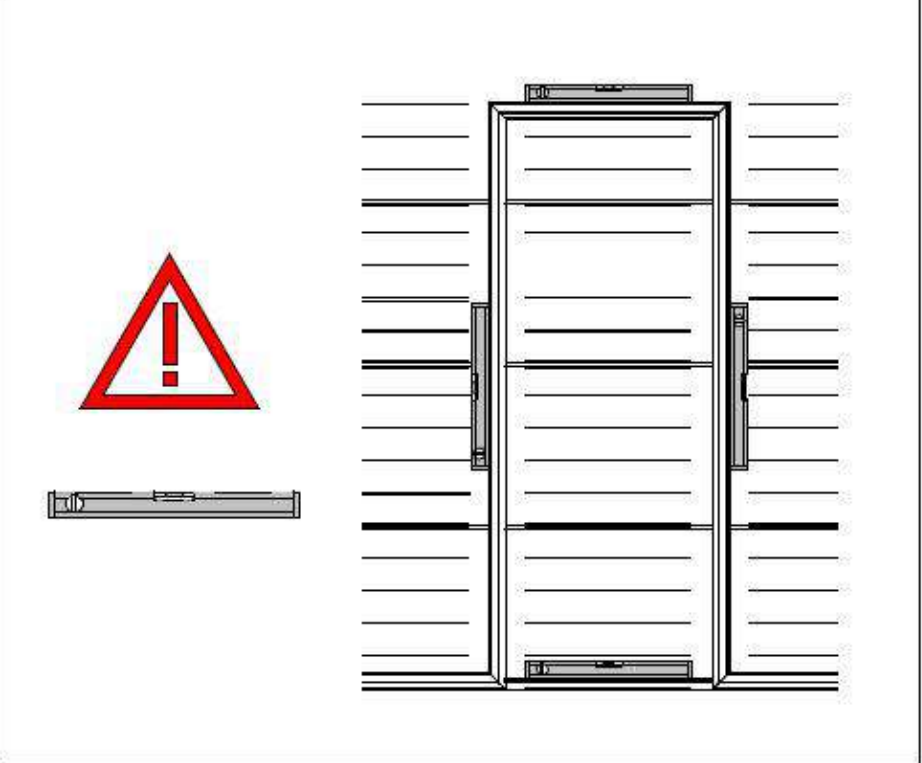
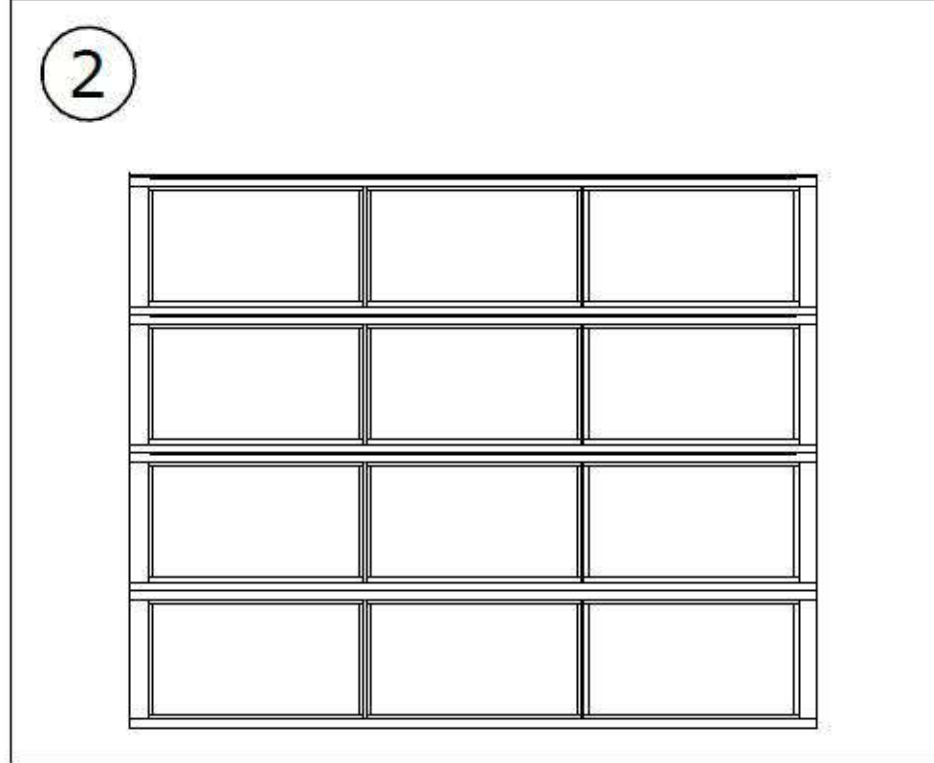
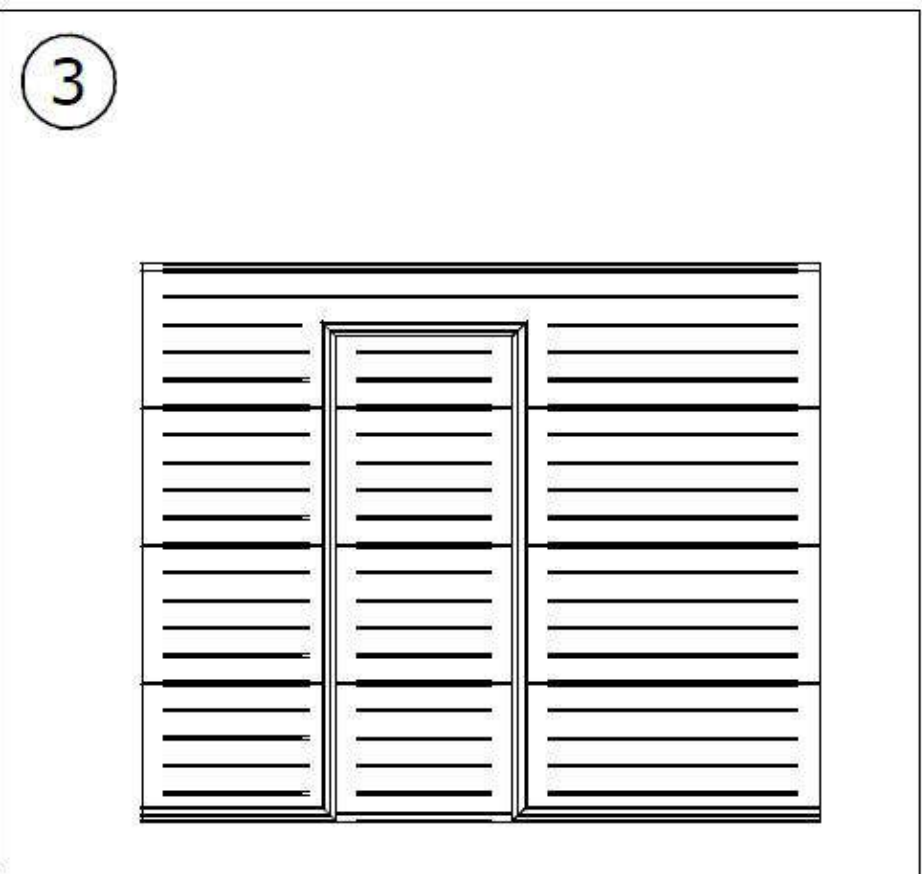
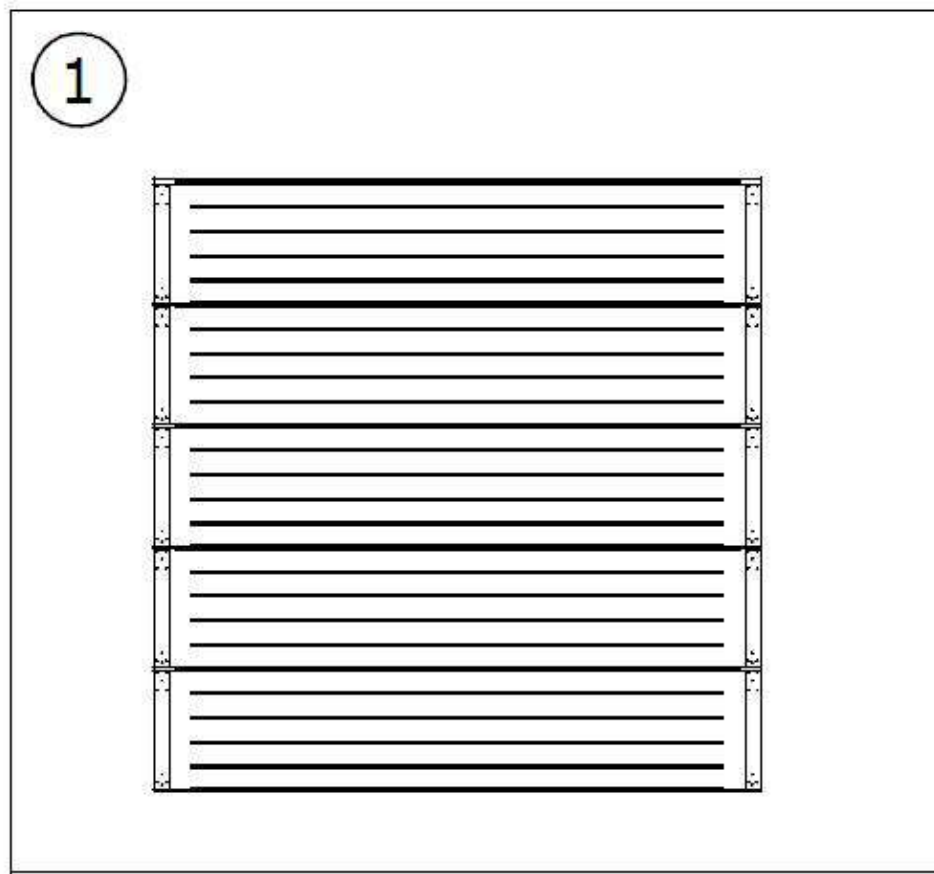
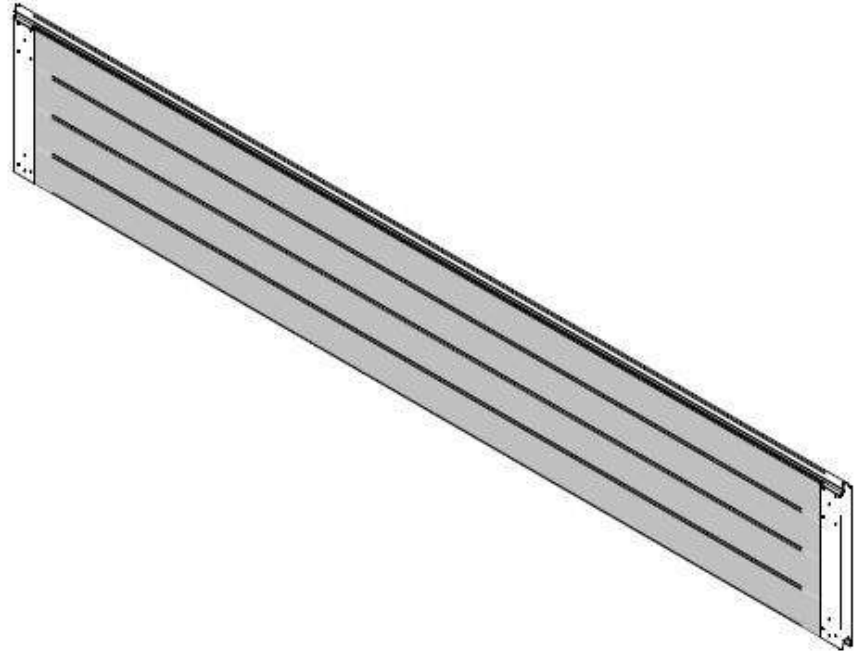
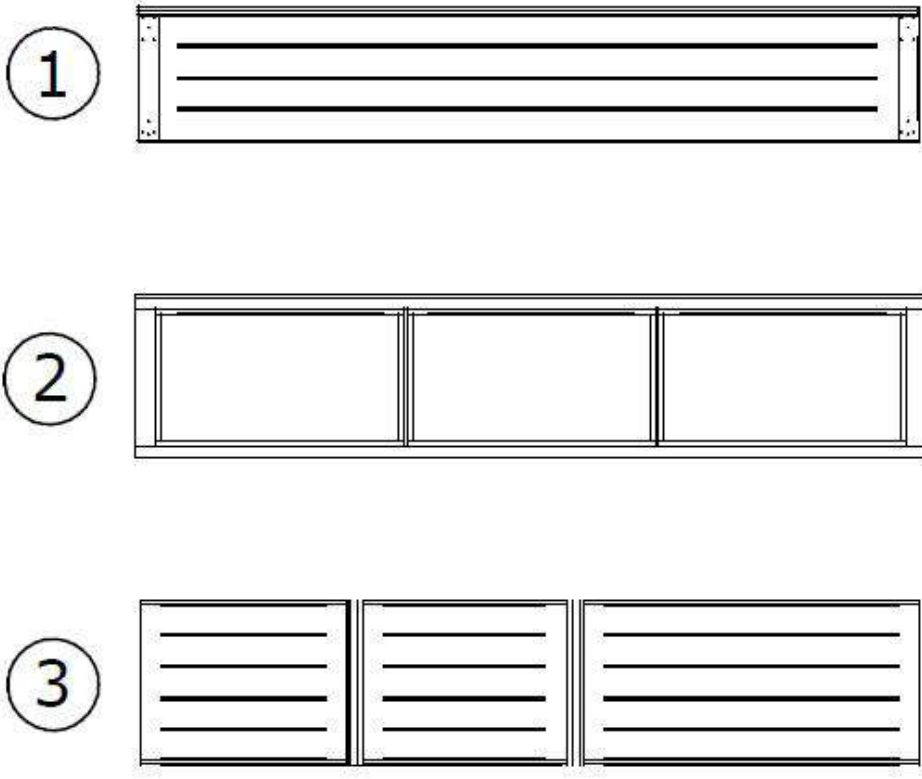

C2

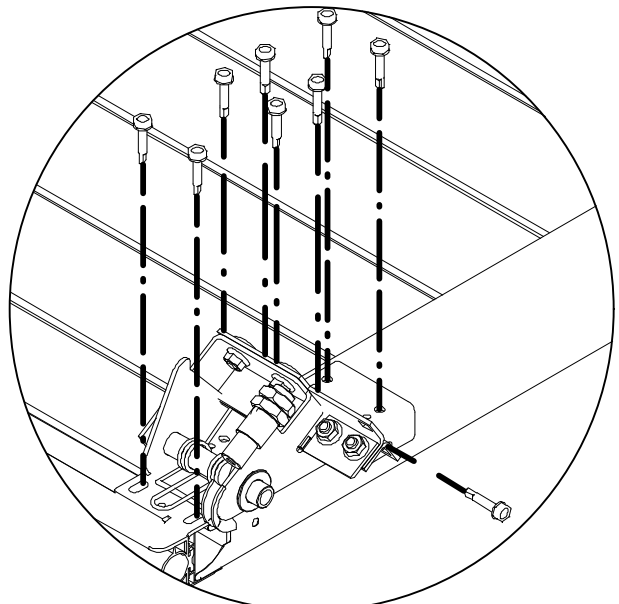
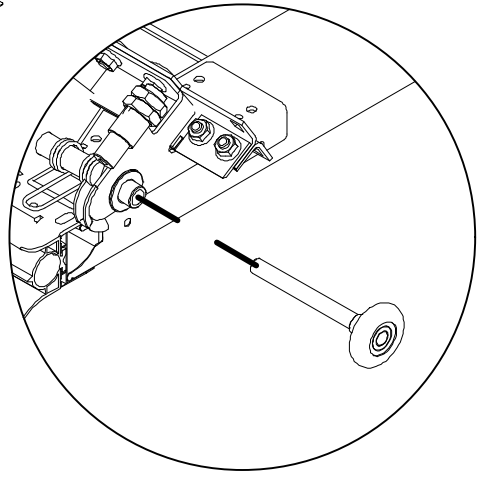
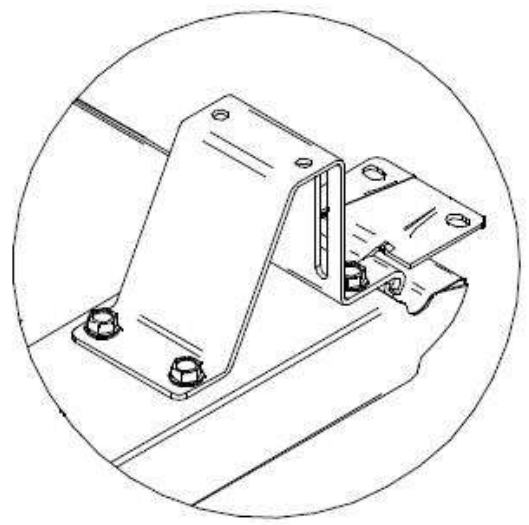
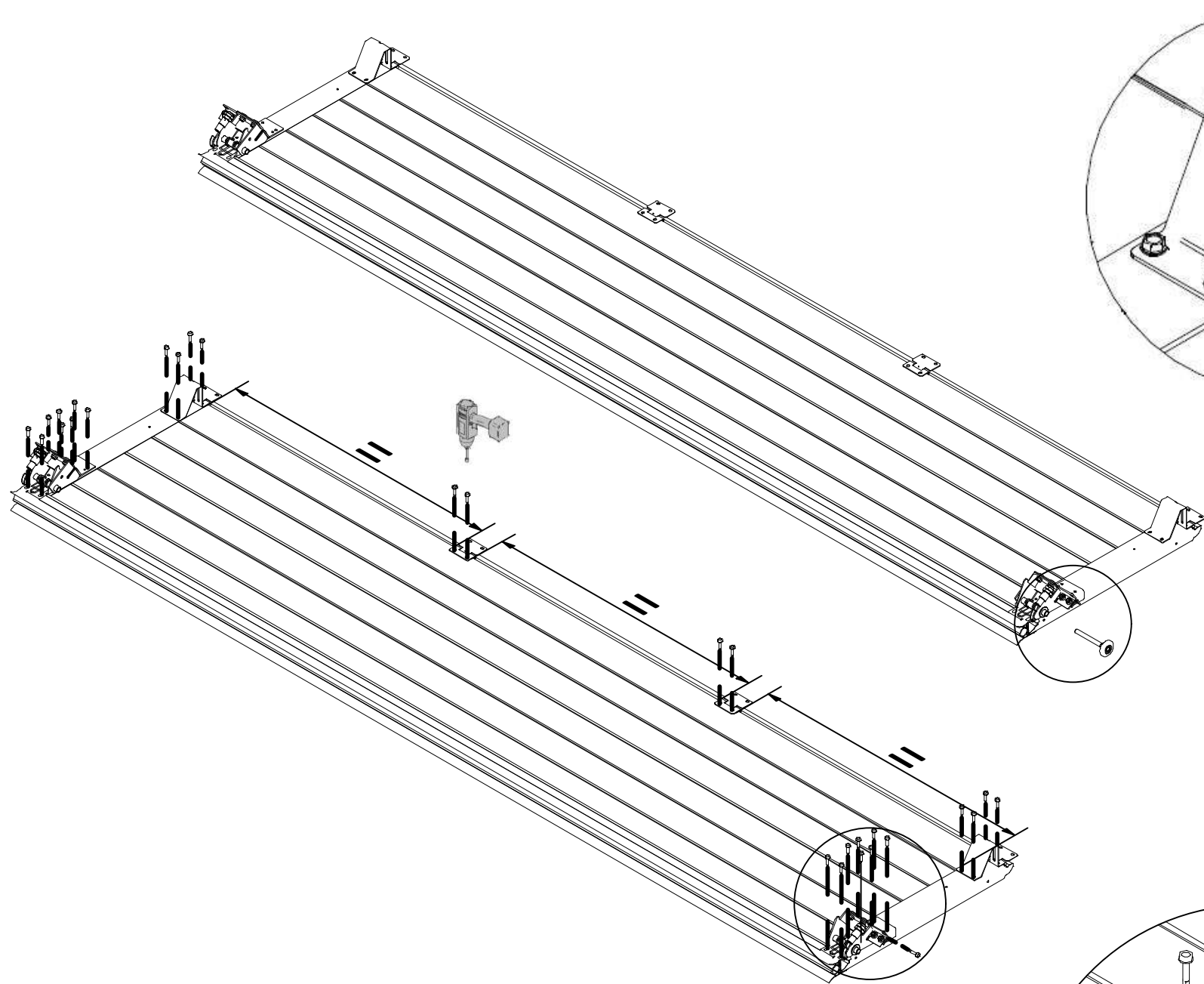
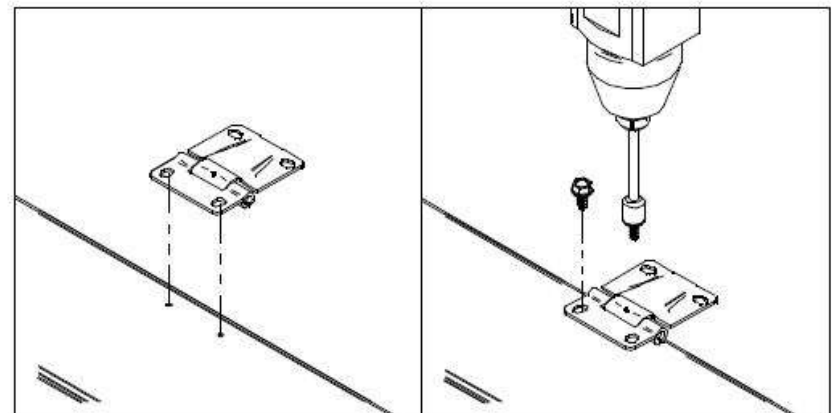
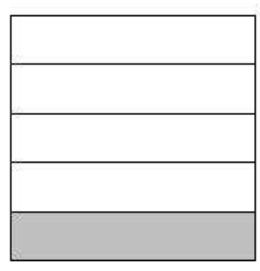

# Options

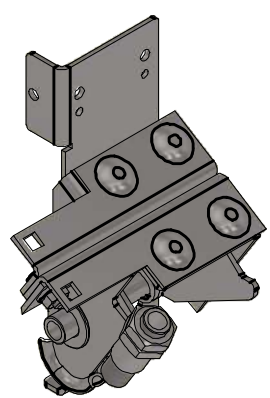
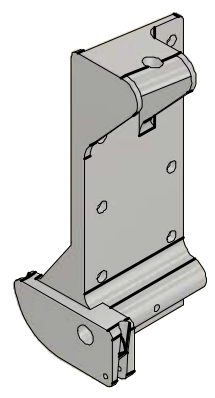
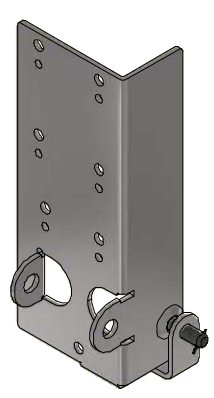

**Riga Door Systems**  
we open the world

Malas, Vetras, Marupe LV-2167, Riga district, Latvia; web: [www.rigadoors.lv](http://www.rigadoors.lv)

Designed by	VPA	Sheet Format	A3	Date	2023-12-08	Installation manual. RS 350		
						RDS 1000	Rev. 2	Sheet 18 / 38

C3

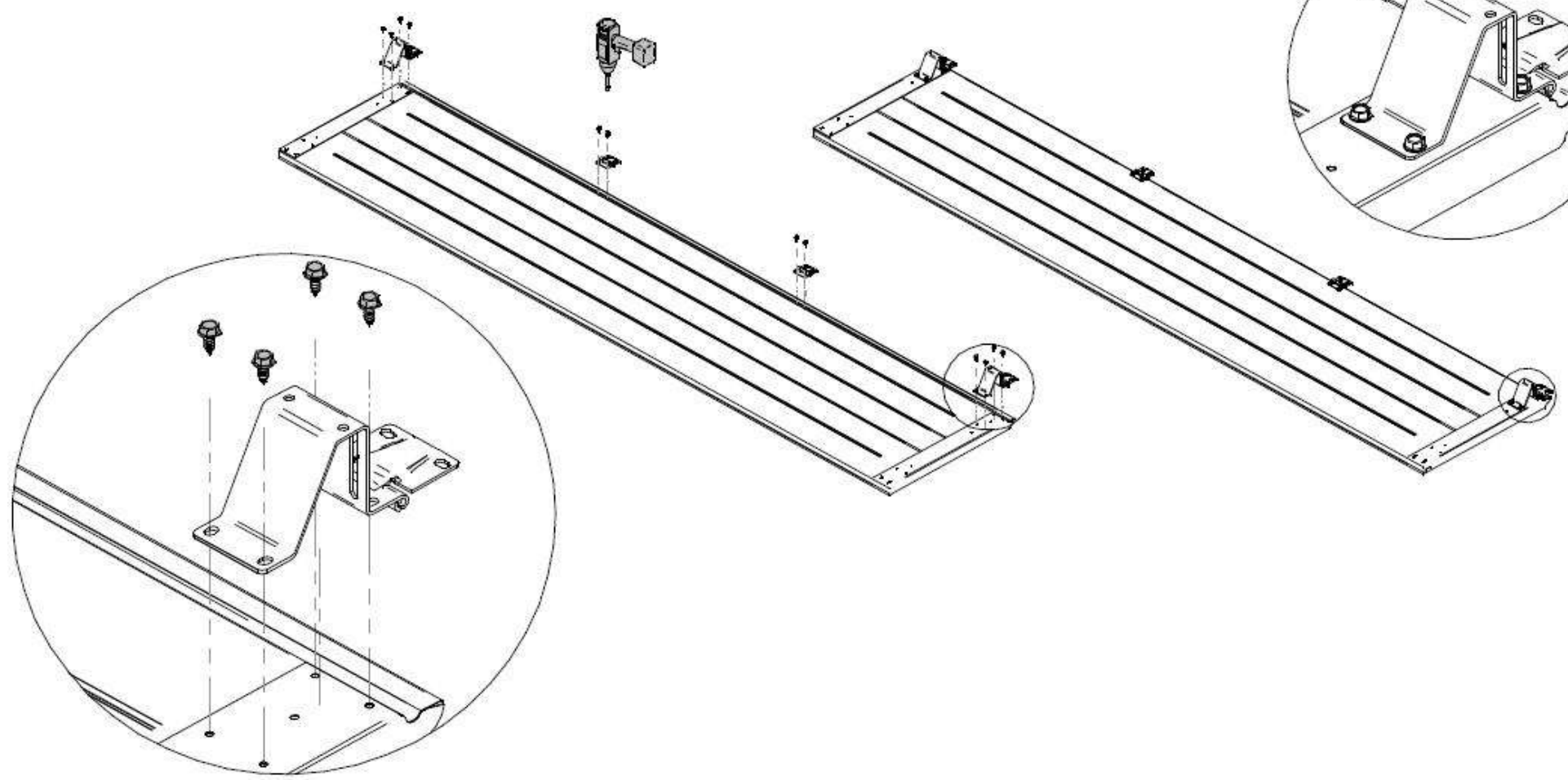
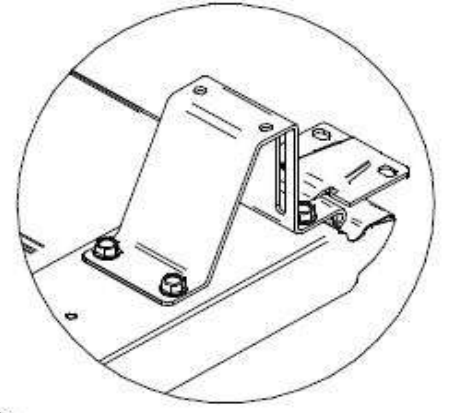
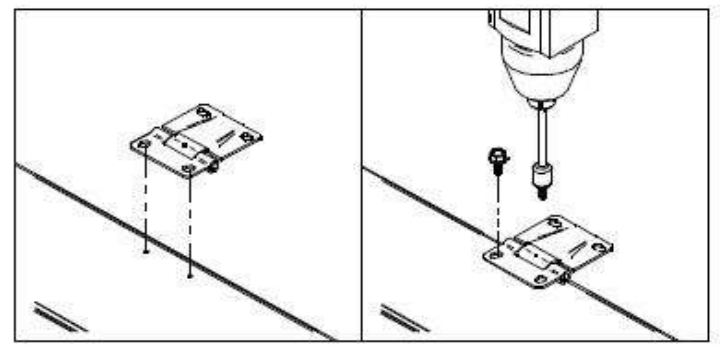
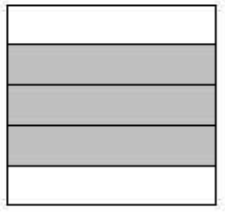

DLW >= 5000 mm

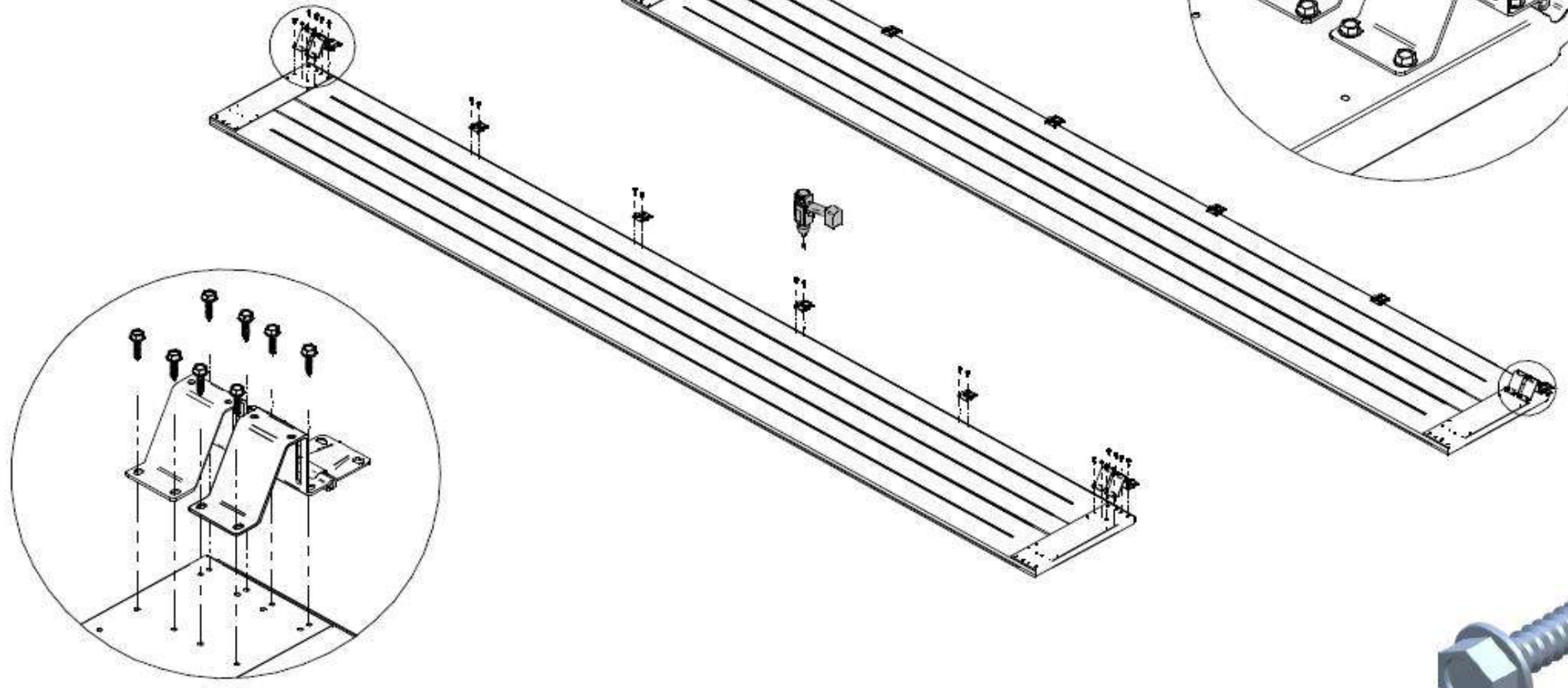
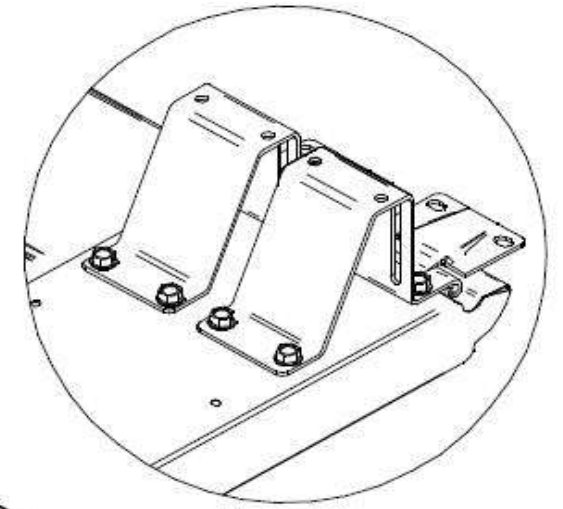

Riga Door Systems  
we open the world

Malas, Vetras, Marupe LV-2167, Riga district, Latvia; web: www.rigadoors.lv

Designed by	VPA	Sheet Format	A3	Date	2023-12-08	Installation manual. RS 350	
						RDS 1000	Rev. 2 / Sheet 19 / 38

C4

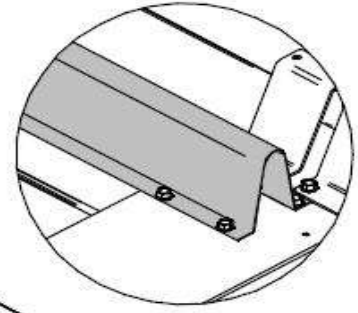
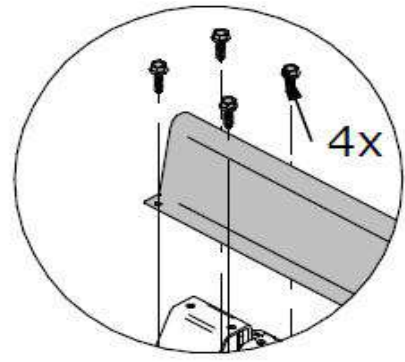
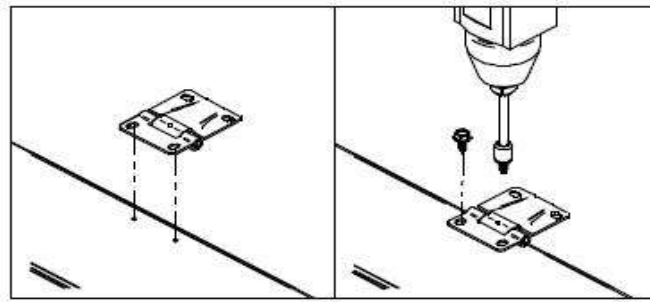
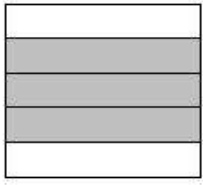

DLW >= 5000 mm

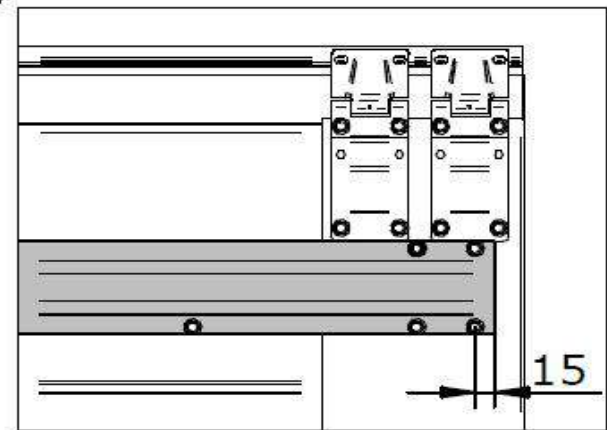
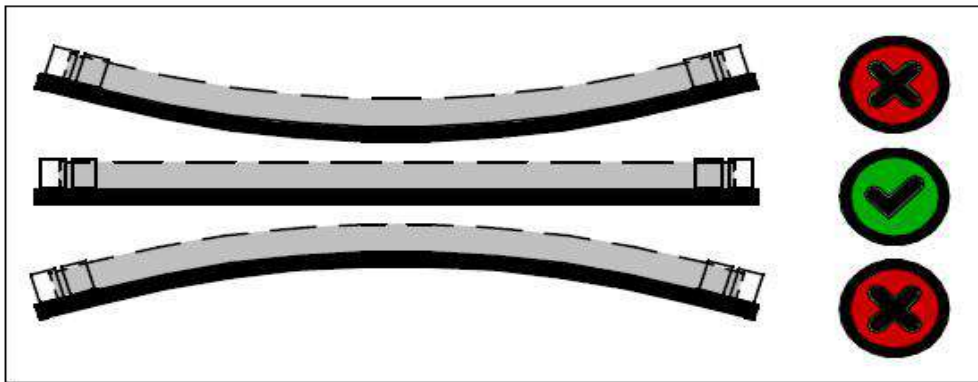
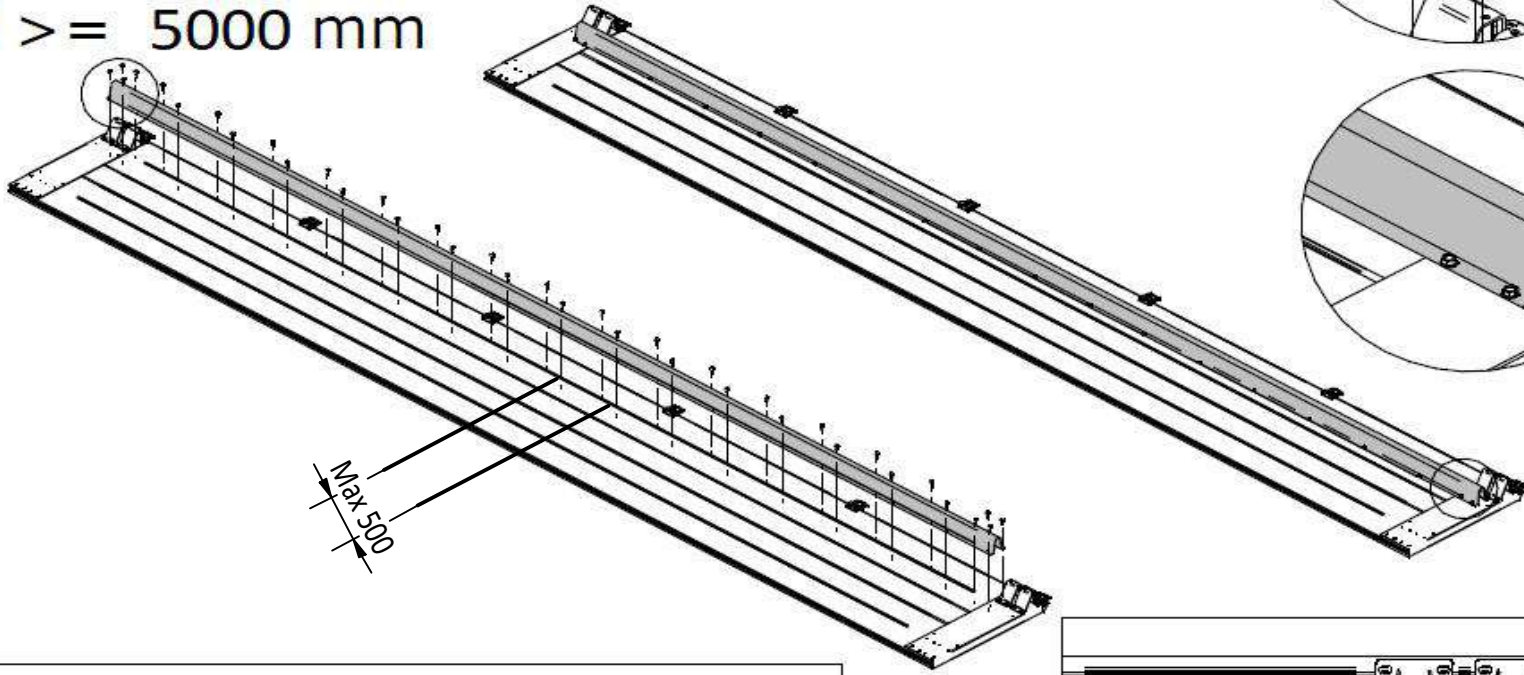

C5

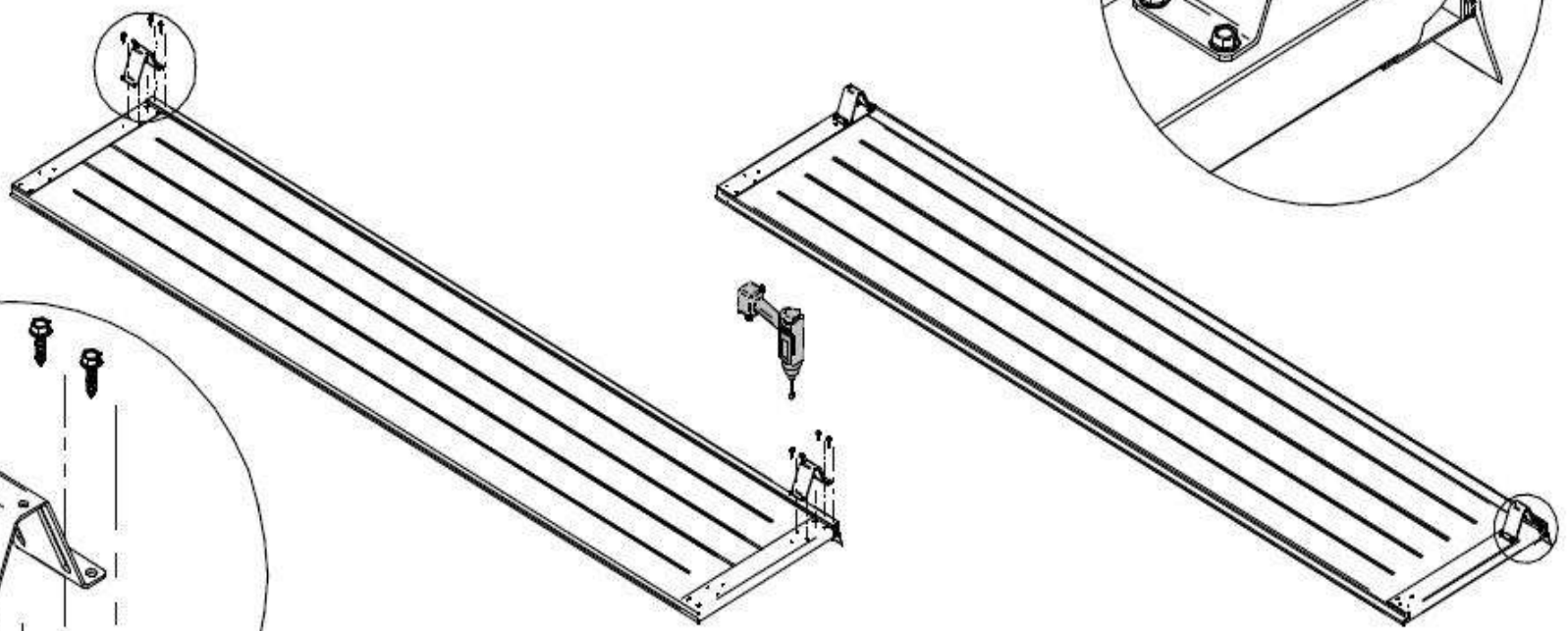
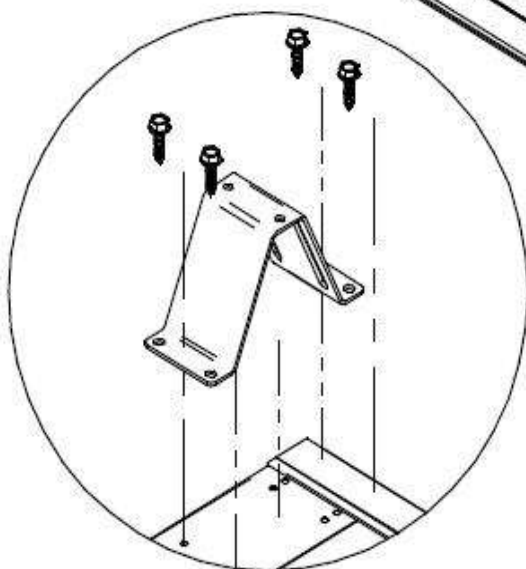
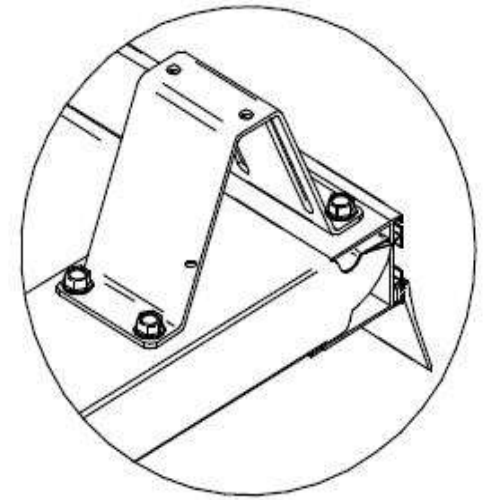
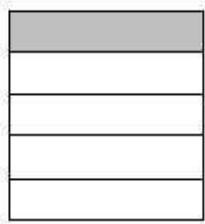

Riga Door Systems  
we open the world

Malas, Vetras, Marupe LV-2167, Riga district, Latvia; web: www.rigadoors.lv

Designed by VPA Sheet Format A3 Date 2023-12-08

Installation manual. RS 350

RDS 1000

Rev. 2

Sheet 20 / 38









C11

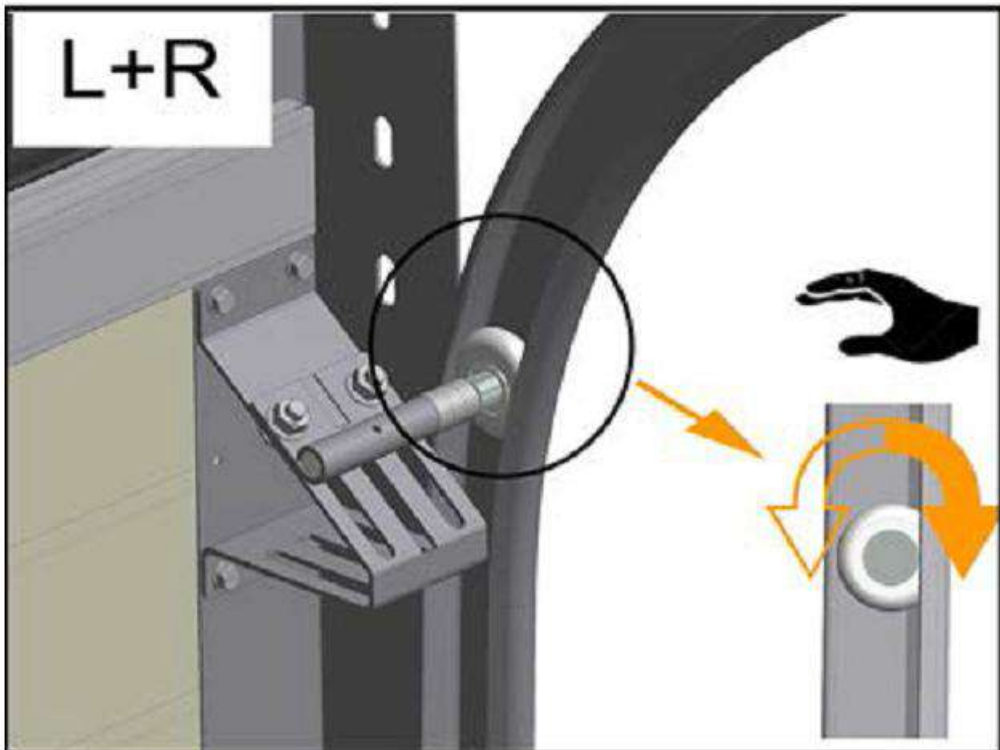
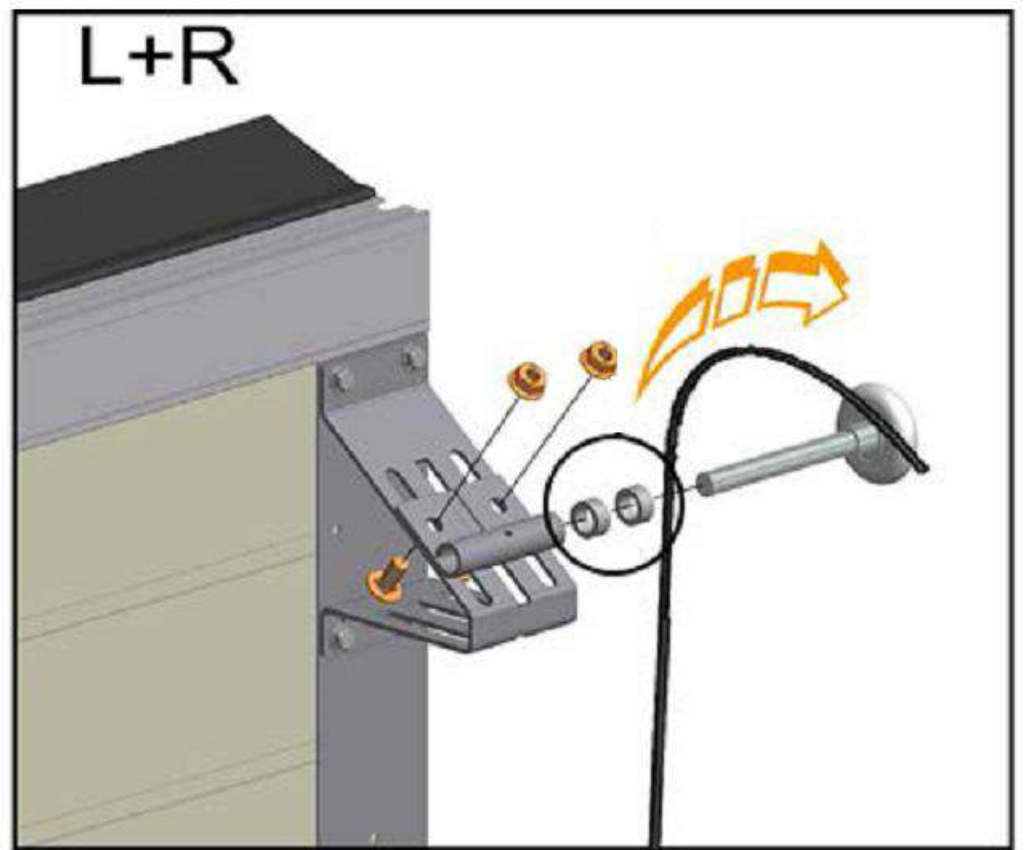
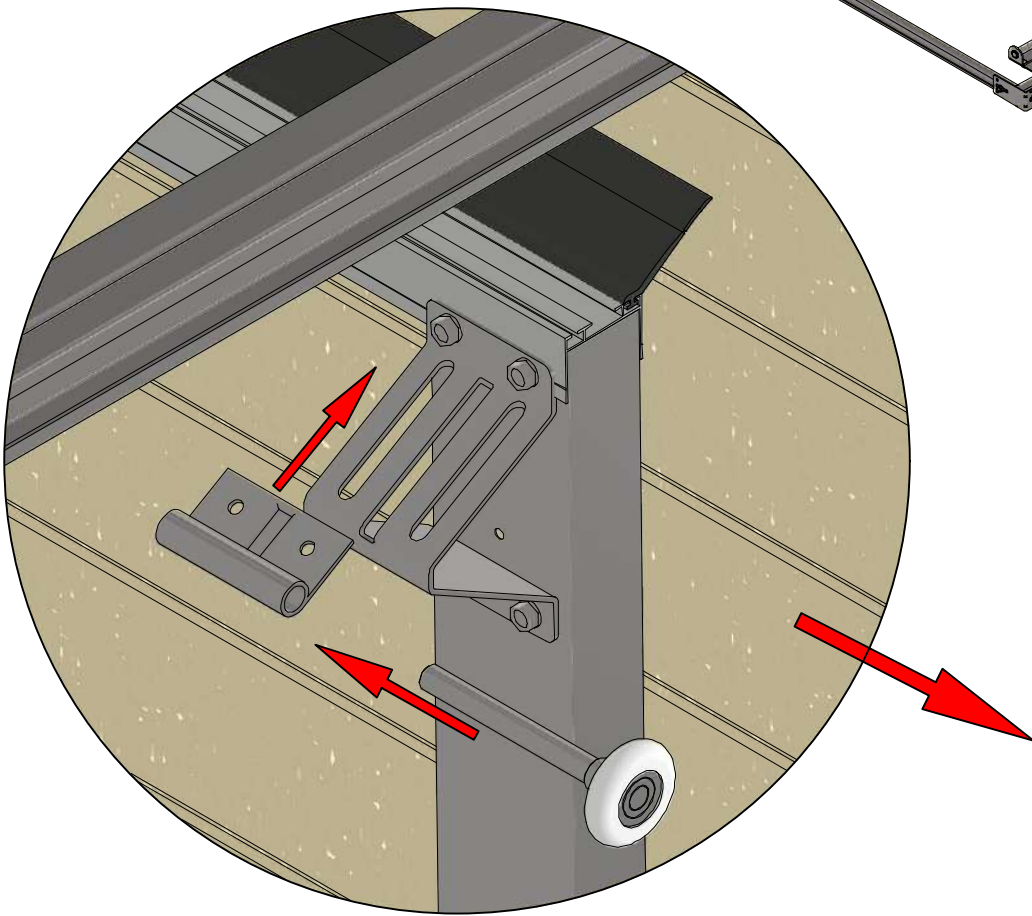
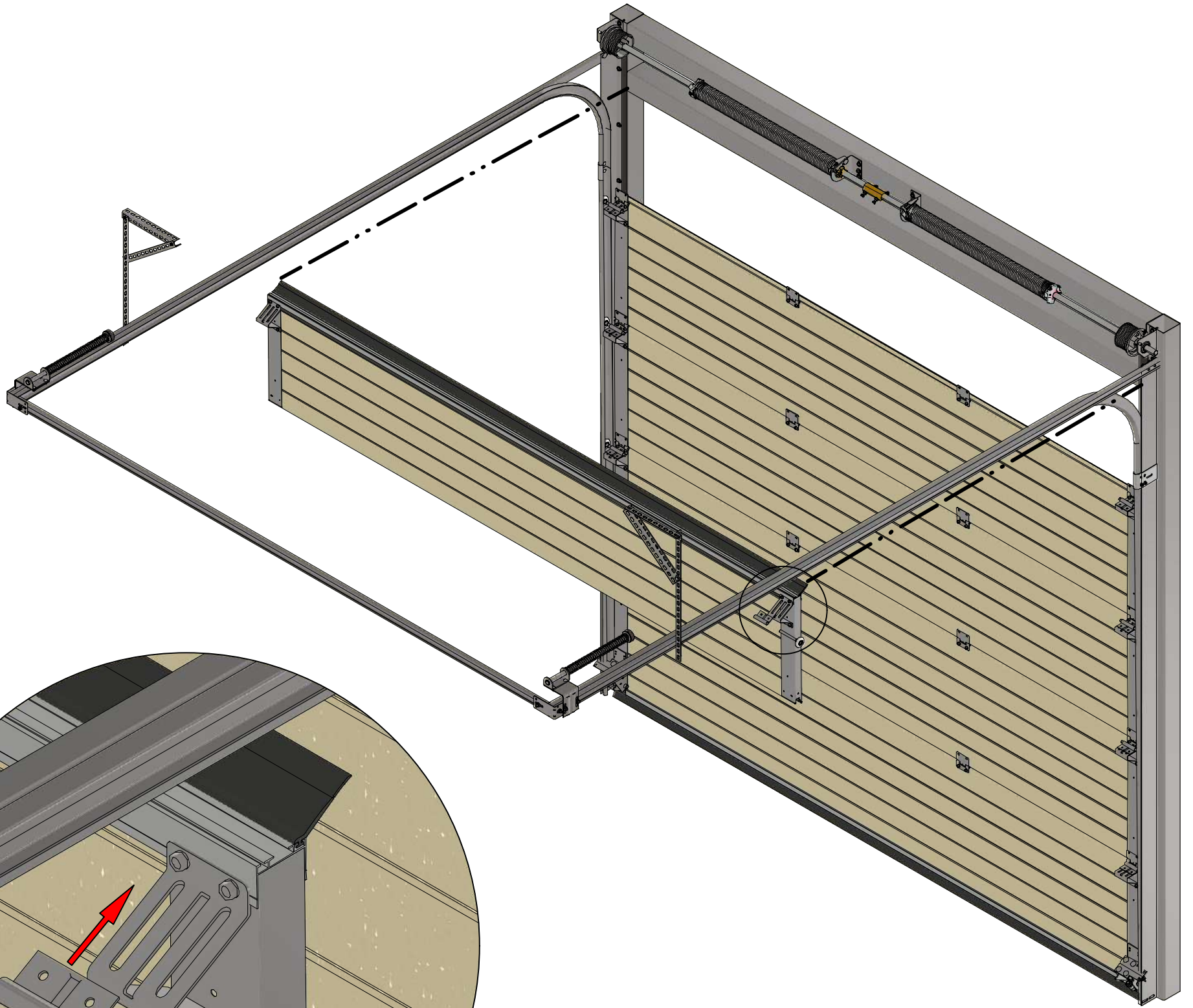

**Riga Door Systems**  
we open the world

Malas, Vetras, Marupe LV-2167, Riga district, Latvia; web: [www.rigadoors.lv](http://www.rigadoors.lv)

Designed by

VPA

Sheet Format

A3

Date

2023-12-08

Installation manual. RS 350

RDS 1000

Rev.

2

Sheet

24 / 38

# Option

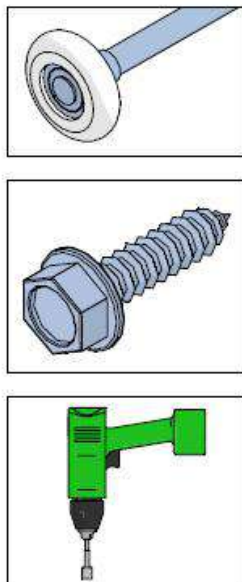
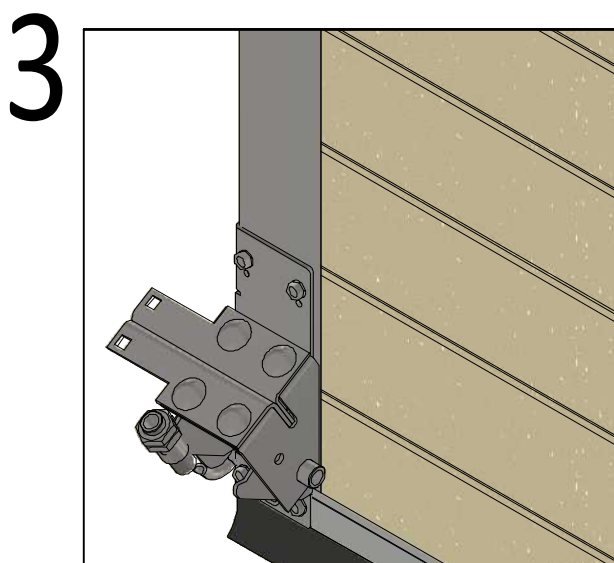
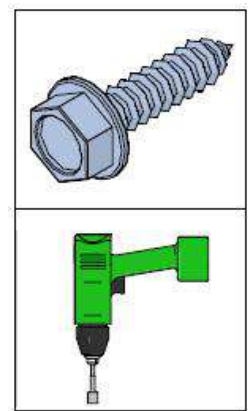
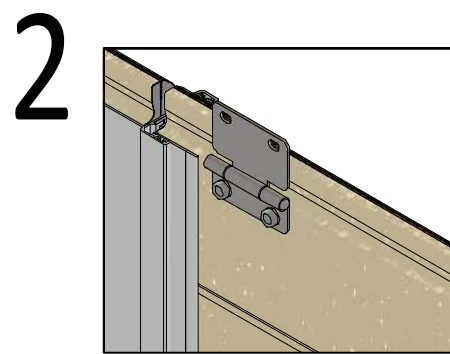
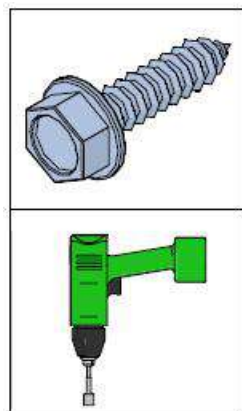
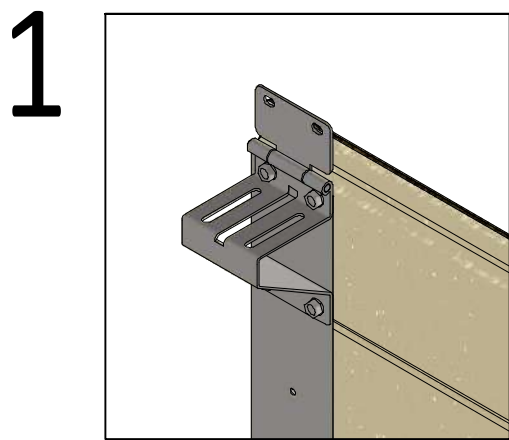
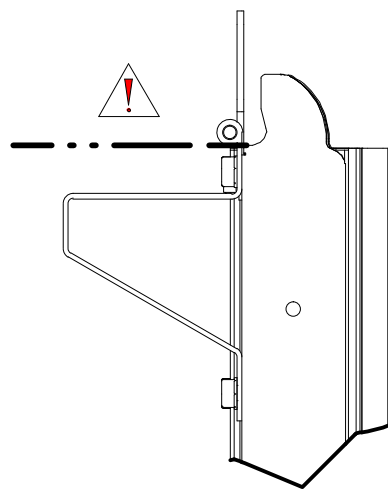
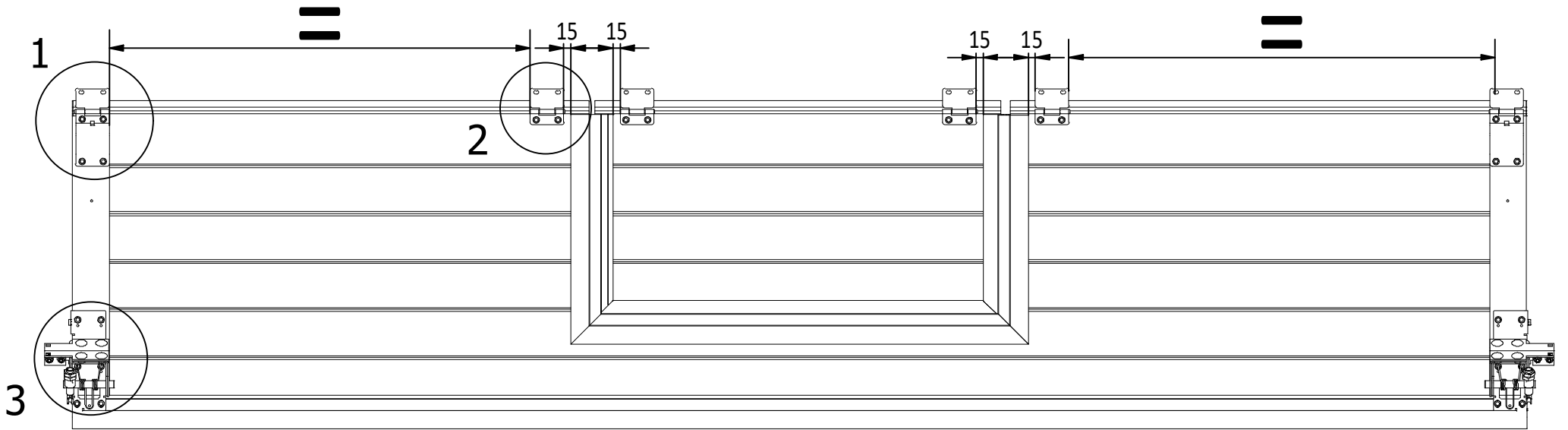

## Options

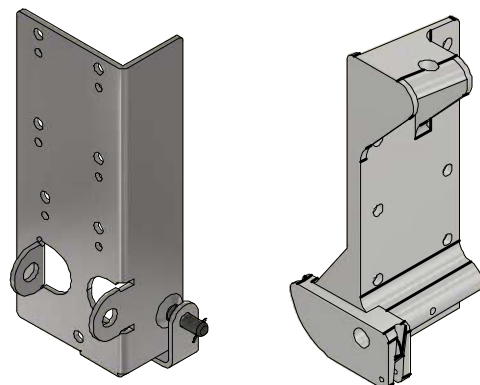

C2.2

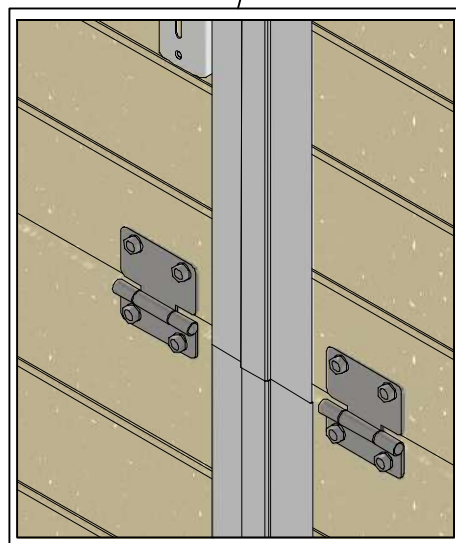
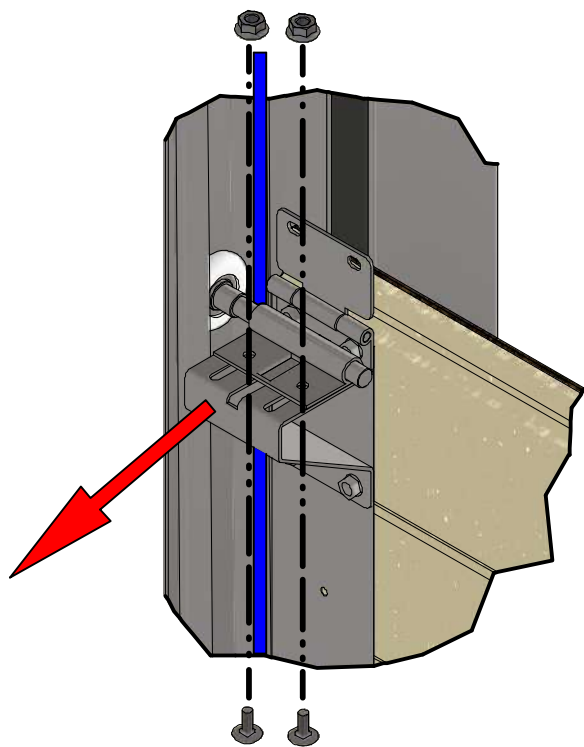
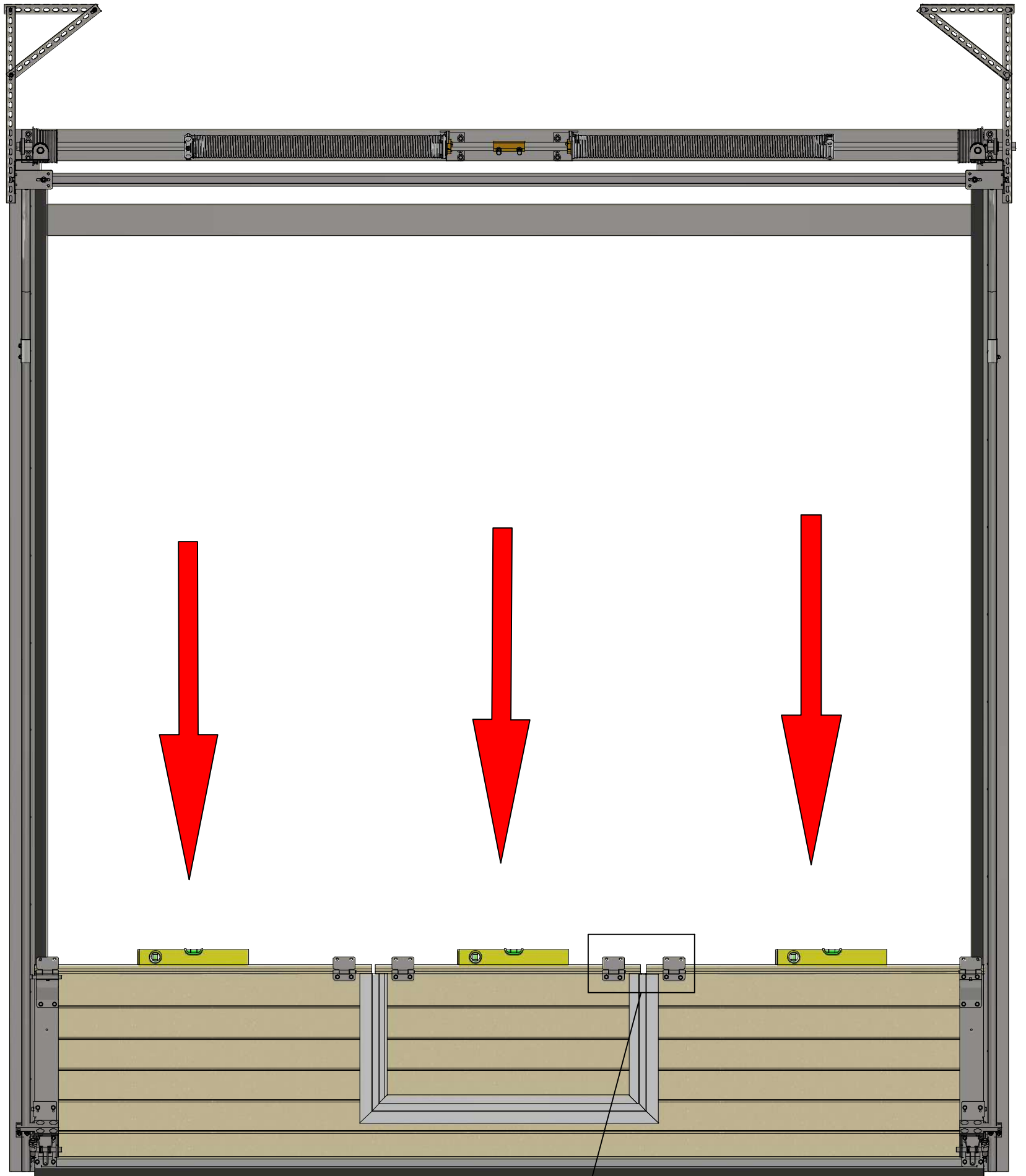
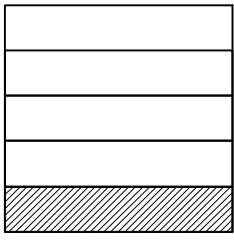

**Riga Door Systems**  
we open the world

Malas, Vetras, Marupe LV-2167, Riga district, Latvia; web: [www.rigadoors.lv](http://www.rigadoors.lv)

Designed by	VPA	Sheet Format	A3	Date	2023-12-08	Installation manual. RS 350	Rev.	Sheet
						RDS 1000	2	26 / 38

C2.3

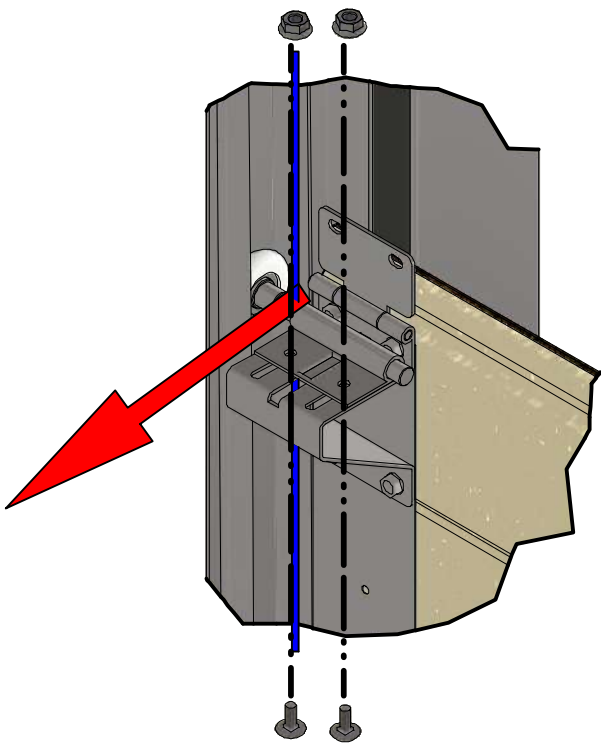
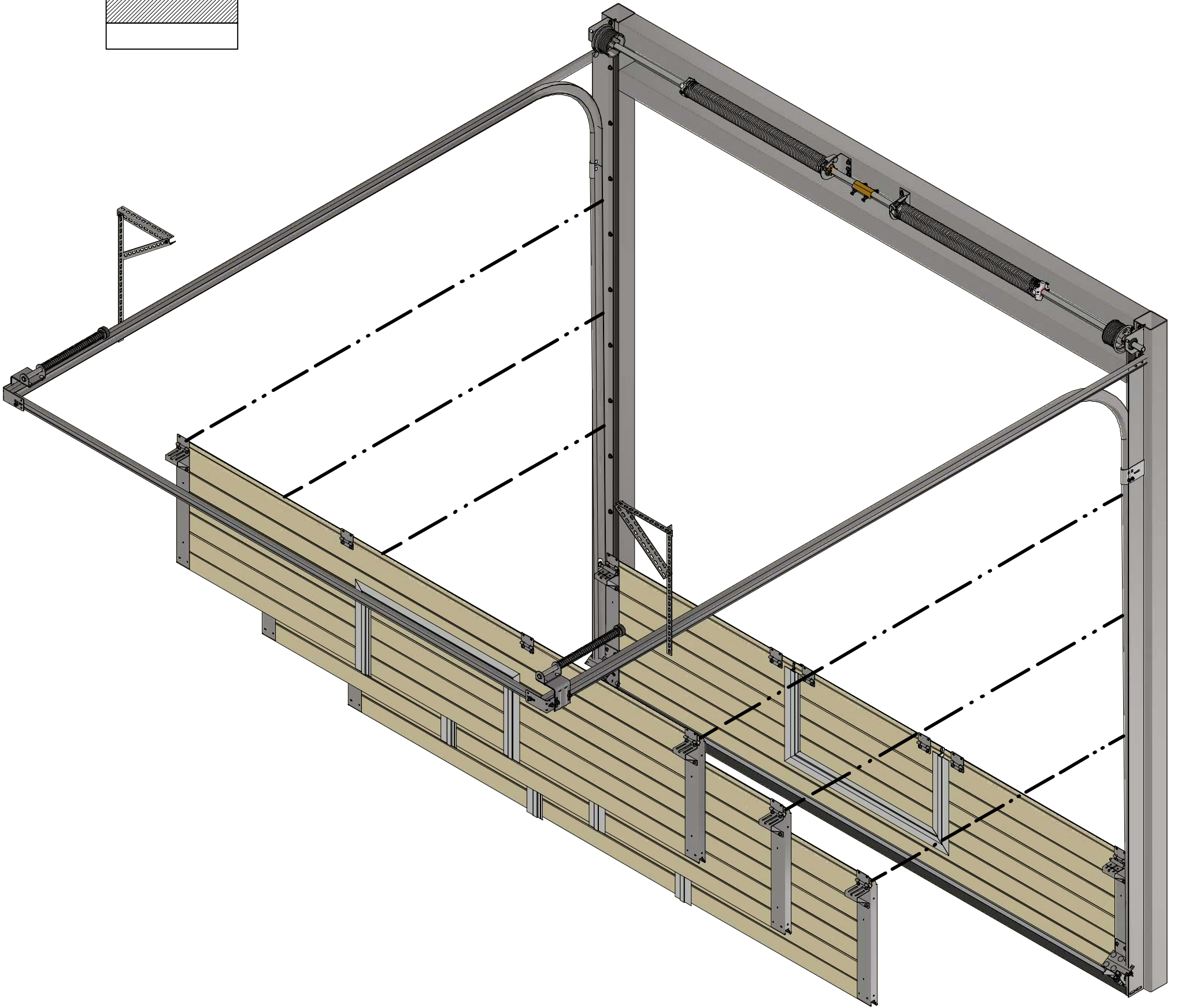
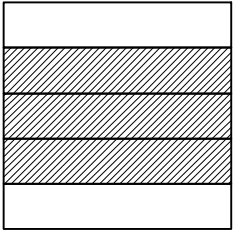

**Riga Door Systems**  
we open the world

Malas, Vetras, Marupe LV-2167, Riga district, Latvia; web: [www.rigadoors.lv](http://www.rigadoors.lv)

Designed by	VPA	Sheet Format	A3	Date	2023-12-08	Installation manual. RS 350		
						RDS 1000	Rev. 2	Sheet 27 / 38

C2.4

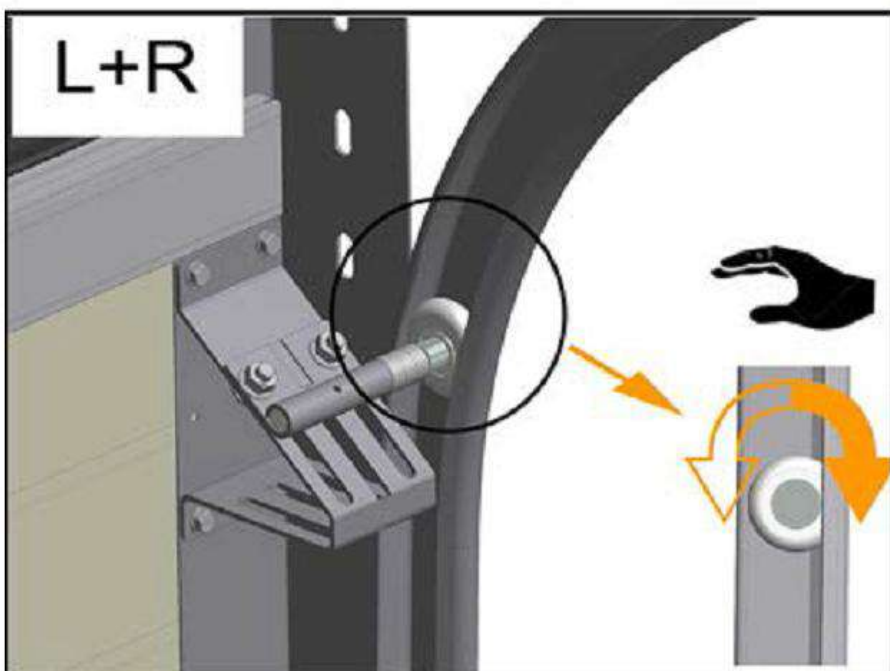
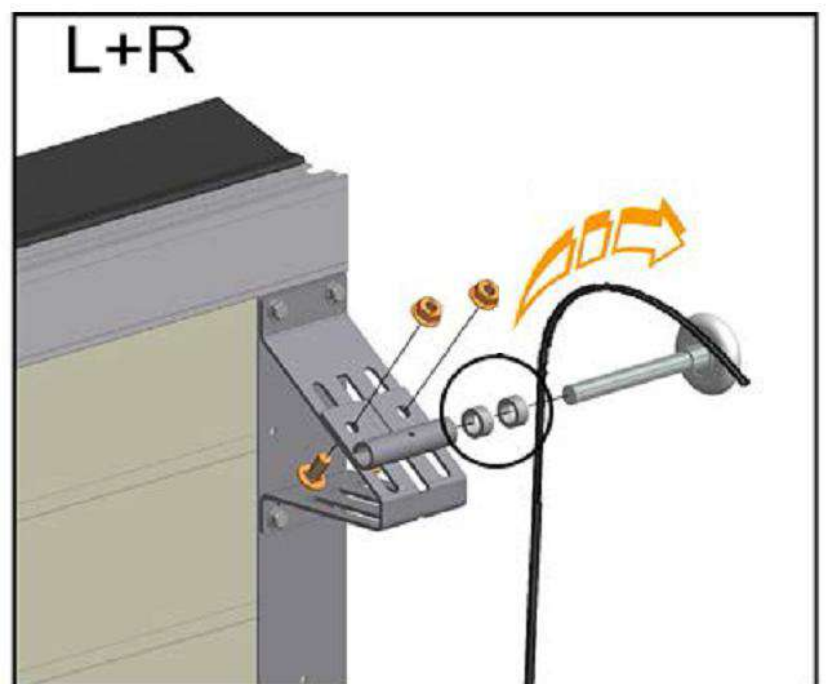
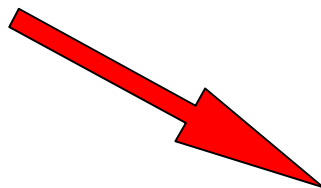
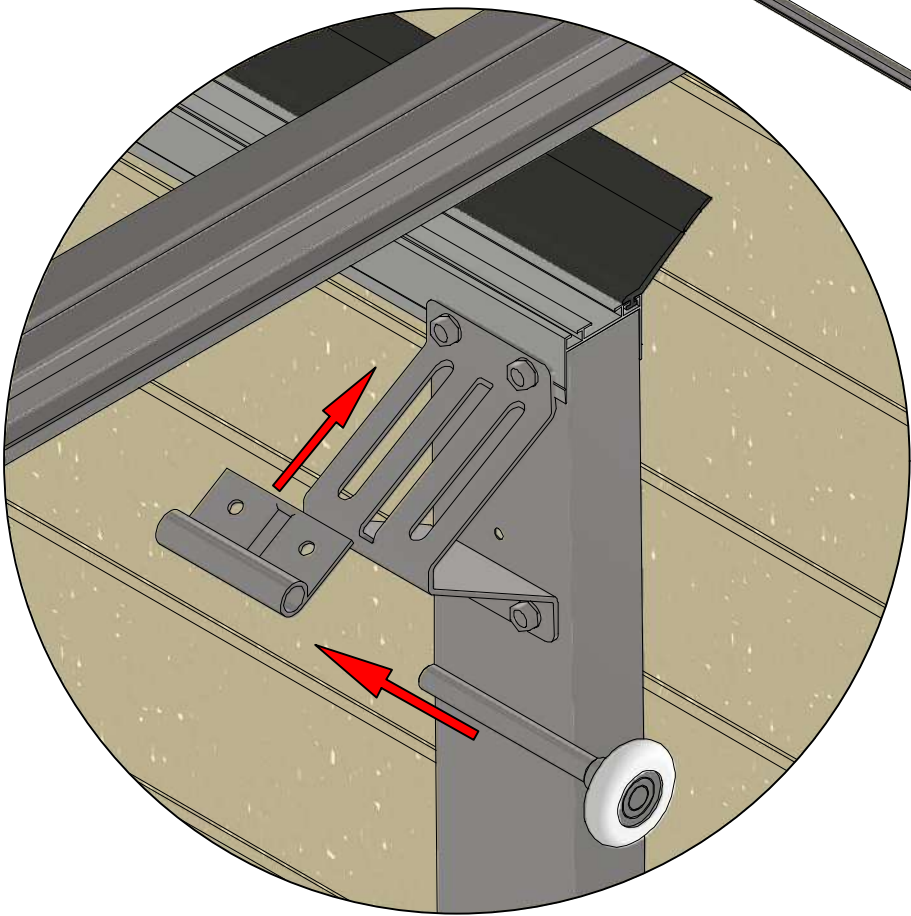
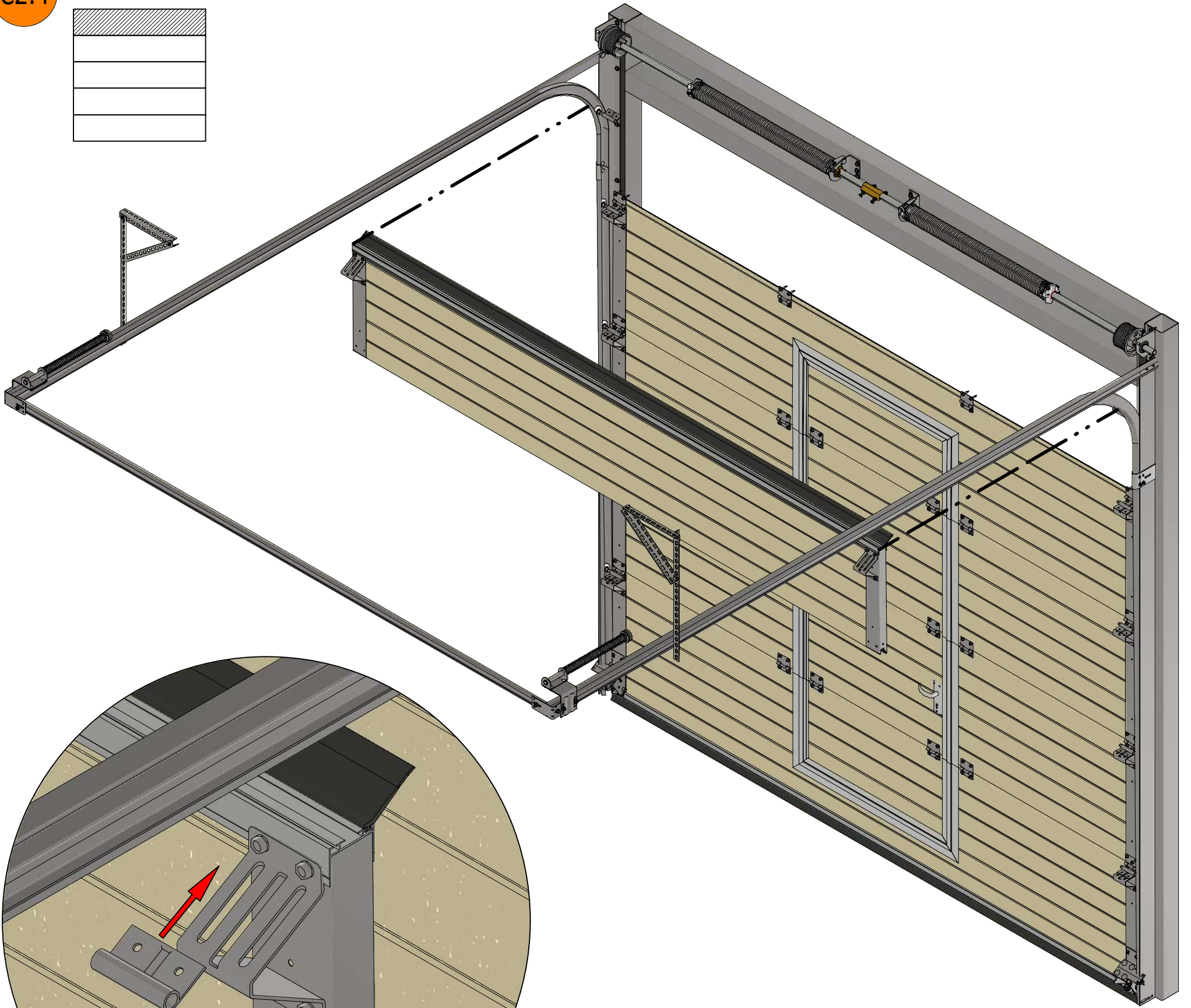
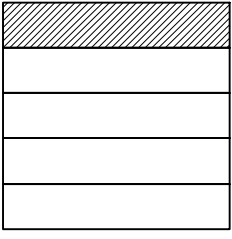

Riga Door Systems  
we open the world

Malas, Vetras, Marupe LV-2167, Riga district, Latvia; web: www.rigadoors.lv

Designed by

VPA

Sheet Format

A3

Date

2023-12-08

Installation manual. RS 350

RDS 1000

Rev.

2

Sheet

28 / 38



D2

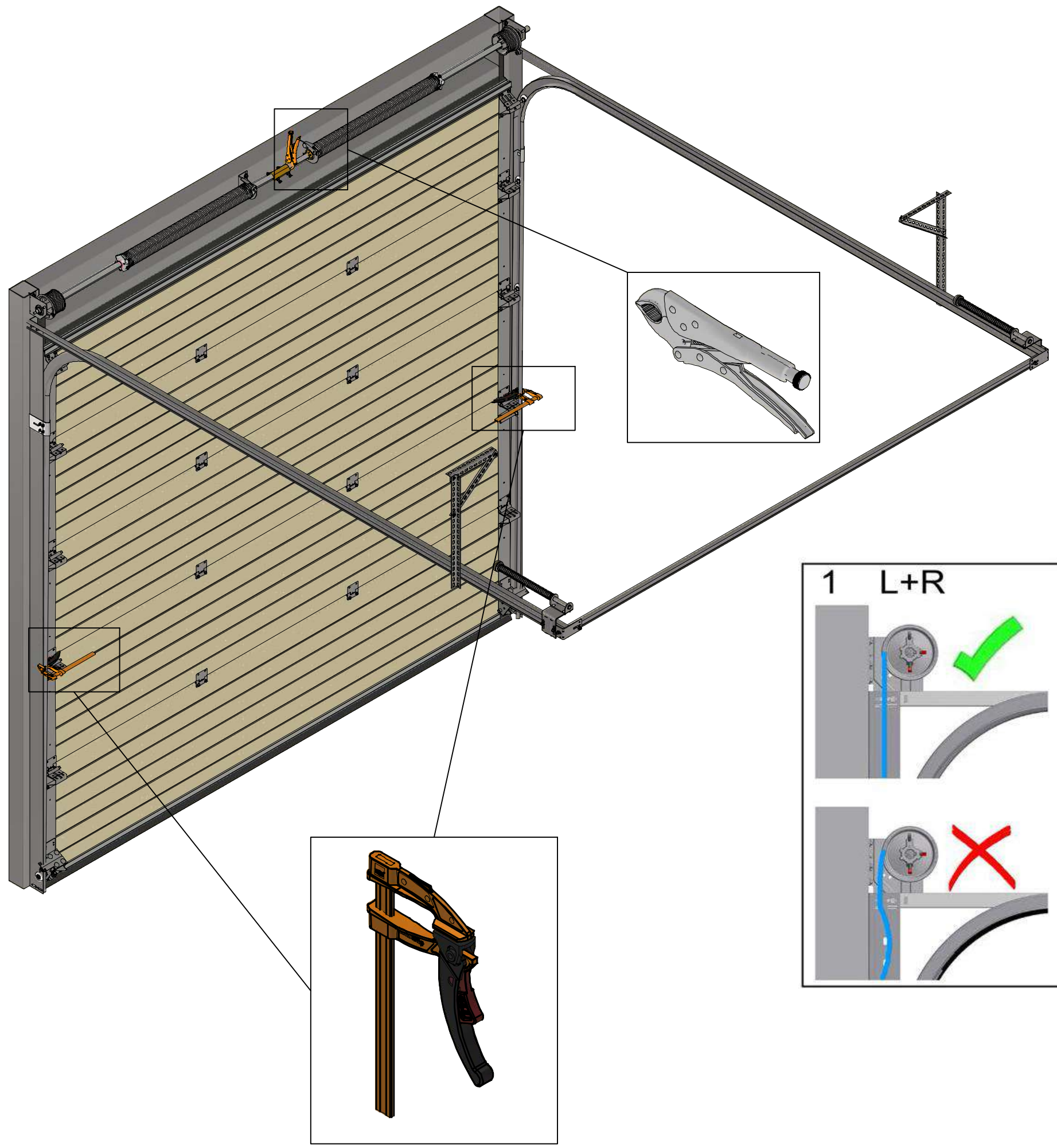

**Riga Door Systems**  
we open the world

Malas, Vetras, Marupe LV-2167, Riga district, Latvia; web: [www.rigadoors.lv](http://www.rigadoors.lv)

Designed by	VPA	Sheet Format	A3	Date	2023-12-08	Installation manual. RS 350		
						RDS 1000	Rev. 2	Sheet 30 / 38

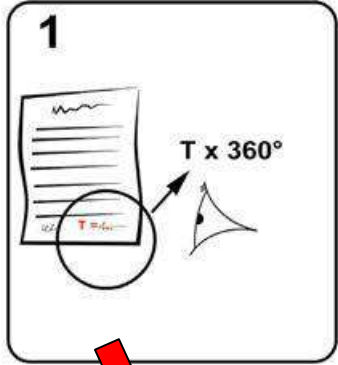
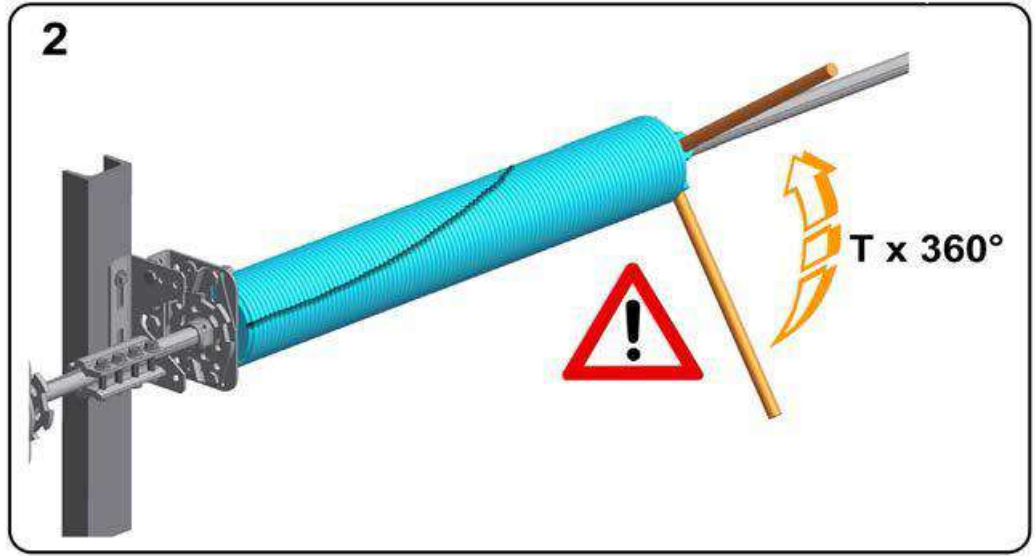
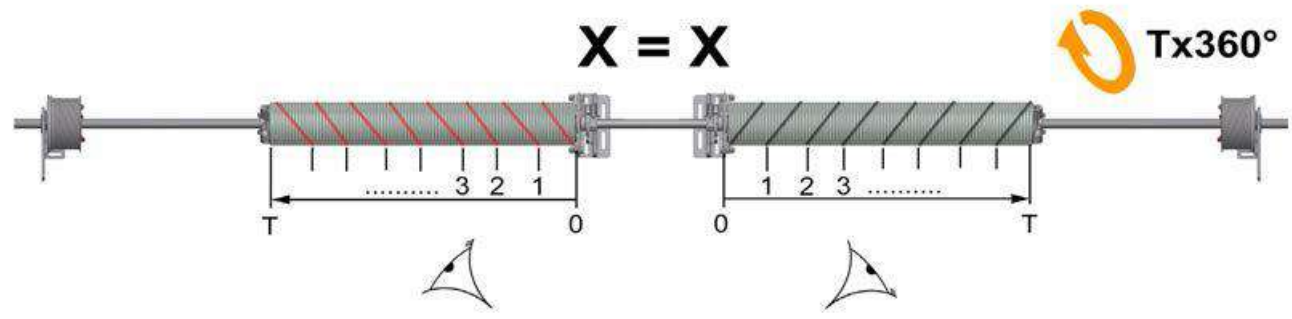

Producer: Riga Door Systems Ltd  
 Malas, Vetras, Marupe LV 2167, Latvia  
 Type: power operated doors  
 RDS1  
 Serial number, year: 314-2022  
 Weight: 10,7kg Cycles: 20 000  
 Springs: 50x6,0x1050 L+R  
**Springs turns: 11,5**  
 Cable drums: FFNL13  
 Opening: 3000x3300(W+H)  
 Panels: RAL9005M/9010  
 500=3 610=3  
 Air permeability class: 3  
 Water penetration class: 3  
 Wind load class: 3  
 Thermal resistance W/(m2K): 1,4  
 EN13241:2003+A2:2016

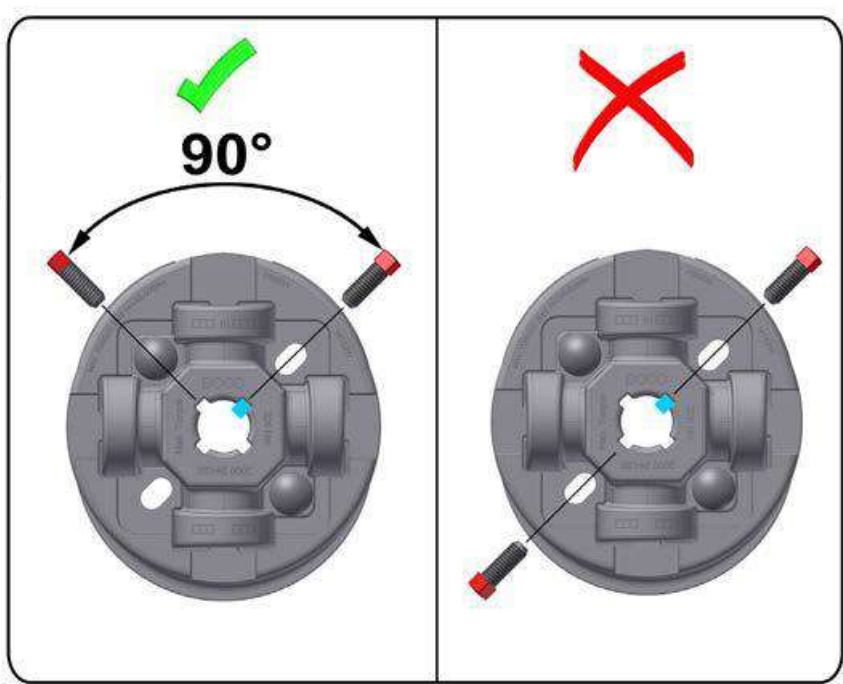
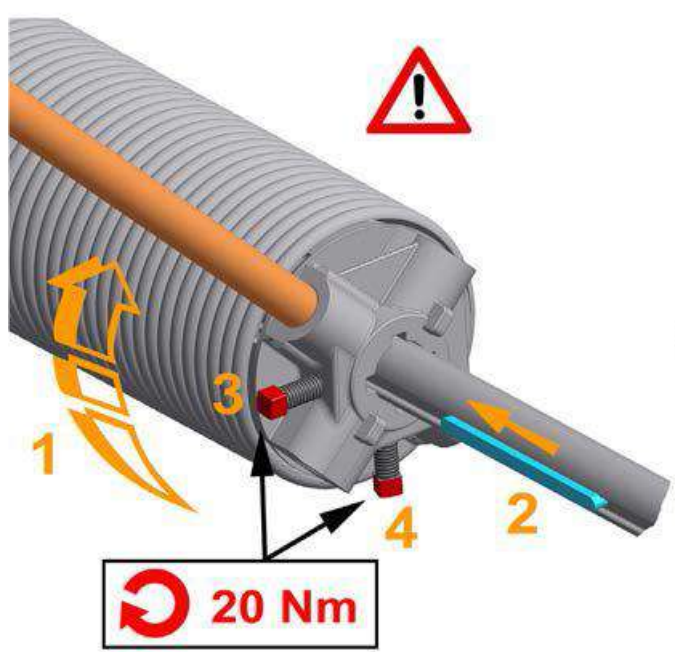

Designed by	VPA	Sheet Format	A3	Date	2023-12-08	Installation manual. RS 350	
						RDS 1000	Rev. 2 / Sheet 31 / 38



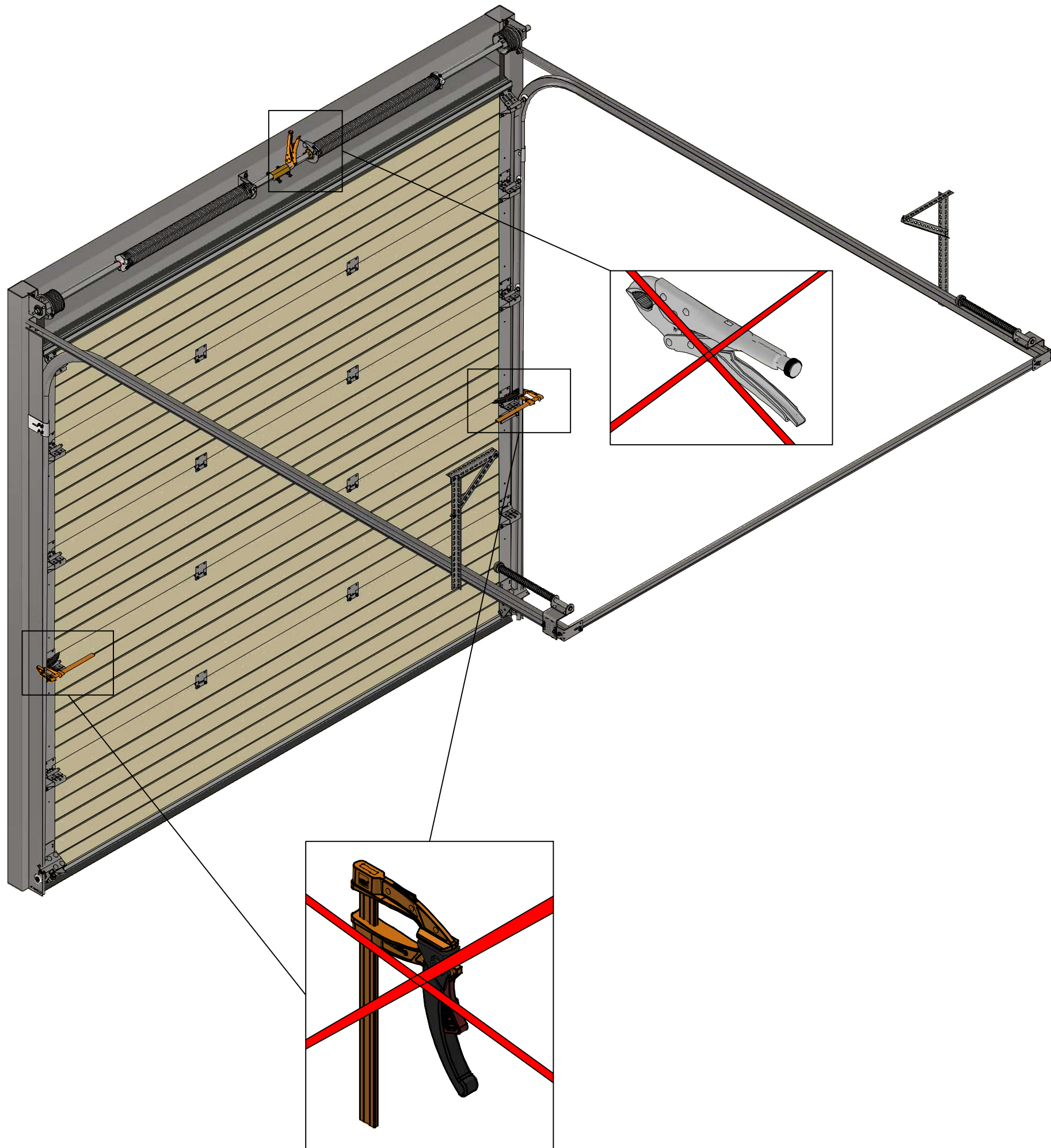

Designed by	VPA	Sheet Format	A3	Date	2023-12-08	Installation manual. RS 350		
						RDS 1000	Rev. 2	Sheet 32 / 38

D5

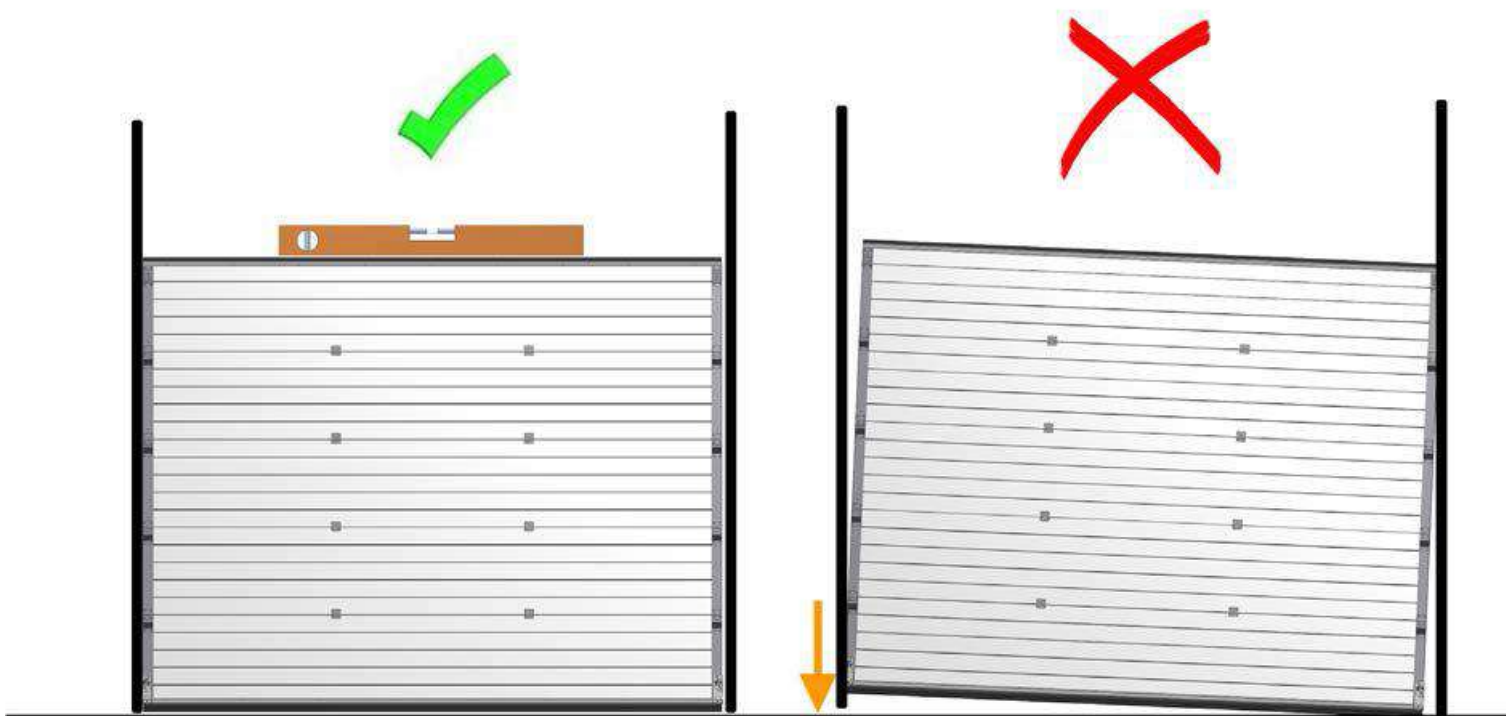
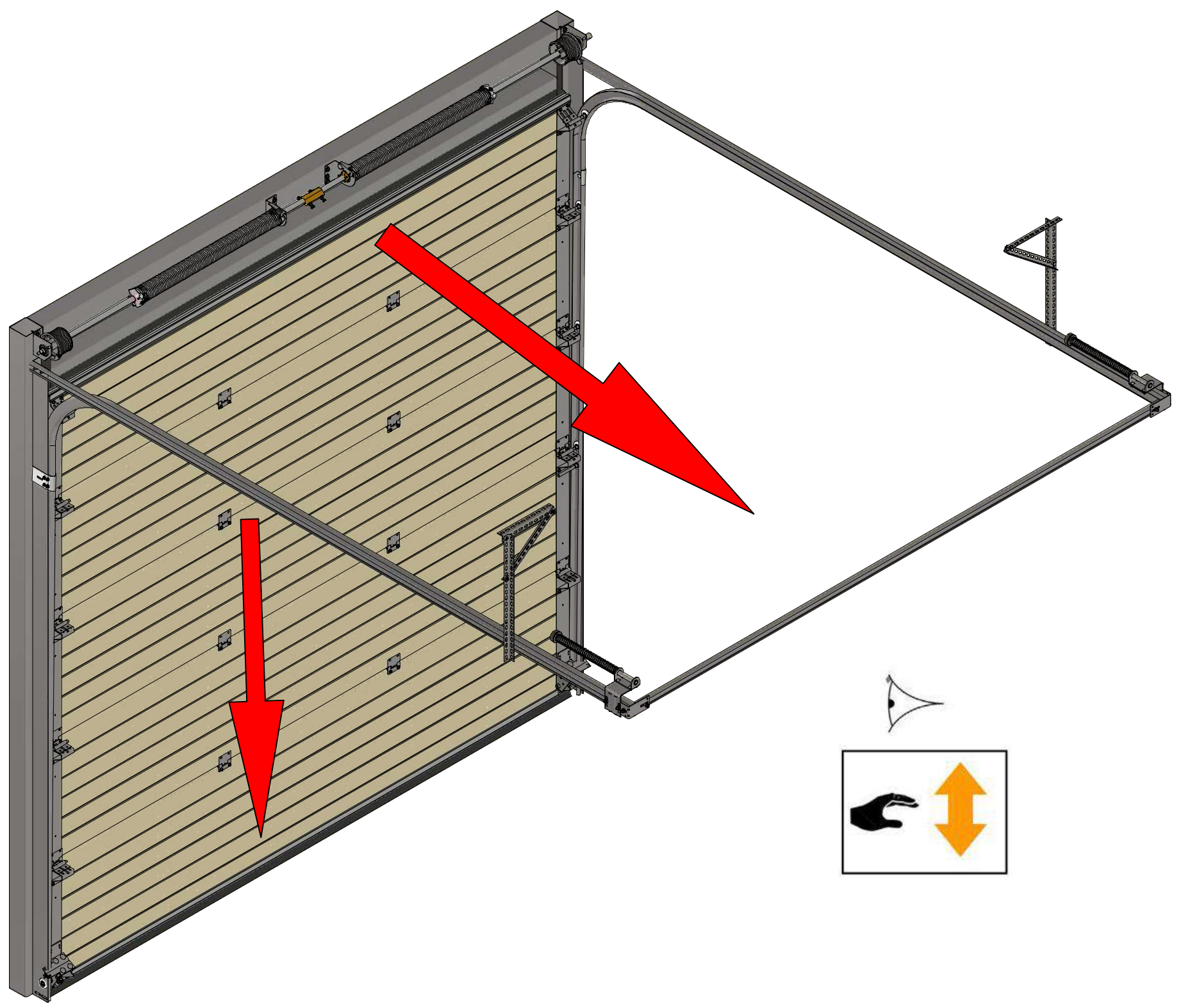

**Riga Door Systems**  
we open the world

Malas, Vetras, Marupe LV-2167, Riga district, Latvia; web: [www.rigadoors.lv](http://www.rigadoors.lv)

Designed by	VPA	Sheet Format	A3	Date	2023-12-08	Installation manual. RS 350		
						RDS 1000	Rev. 2	Sheet 33 / 38

D6

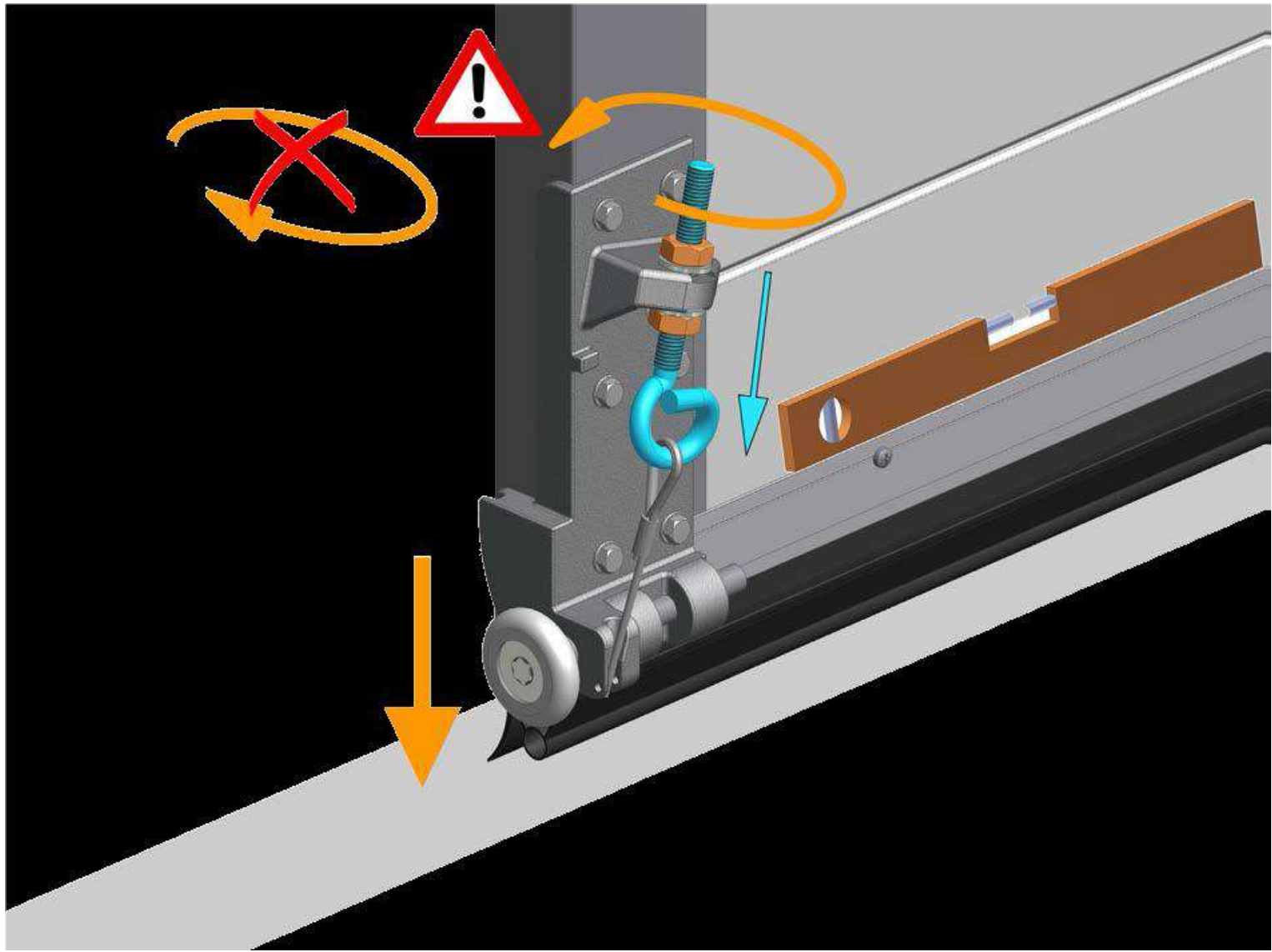

### Option

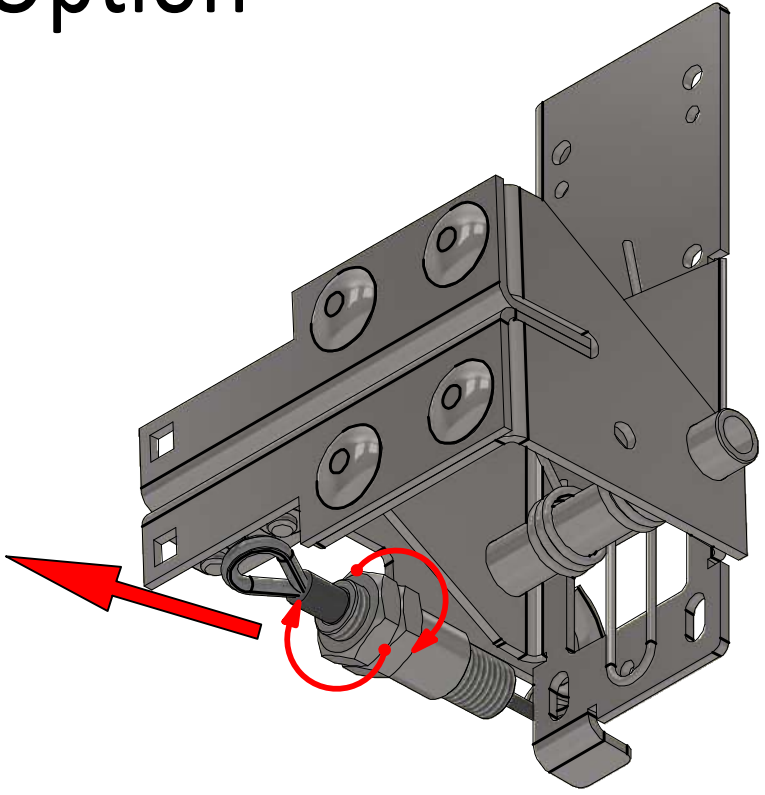

D7

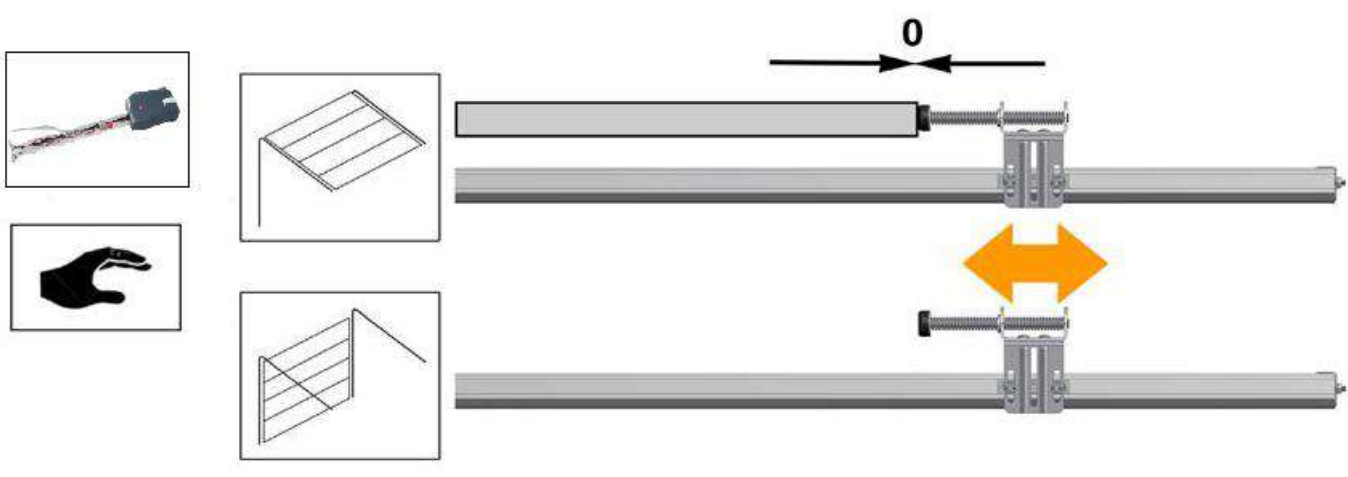
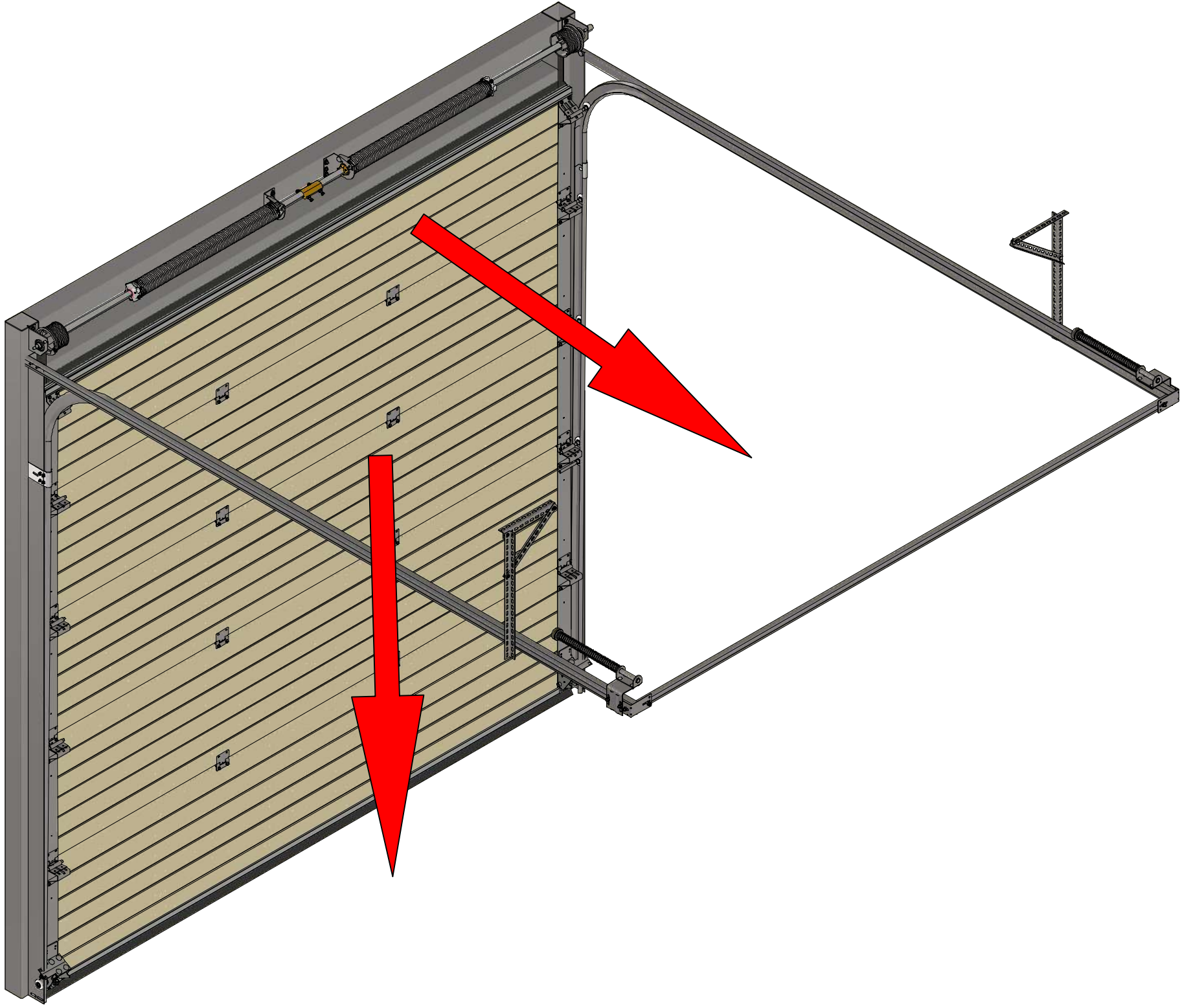

**Riga Door Systems**  
we open the world

Malas, Vetras, Marupe LV-2167, Riga district, Latvia; web: [www.rigadoors.lv](http://www.rigadoors.lv)

Designed by	VPA	Sheet Format	A3	Date	2023-12-08	Installation manual. RS 350		
						RDS 1000	Rev. 2	Sheet 35 / 38

D8

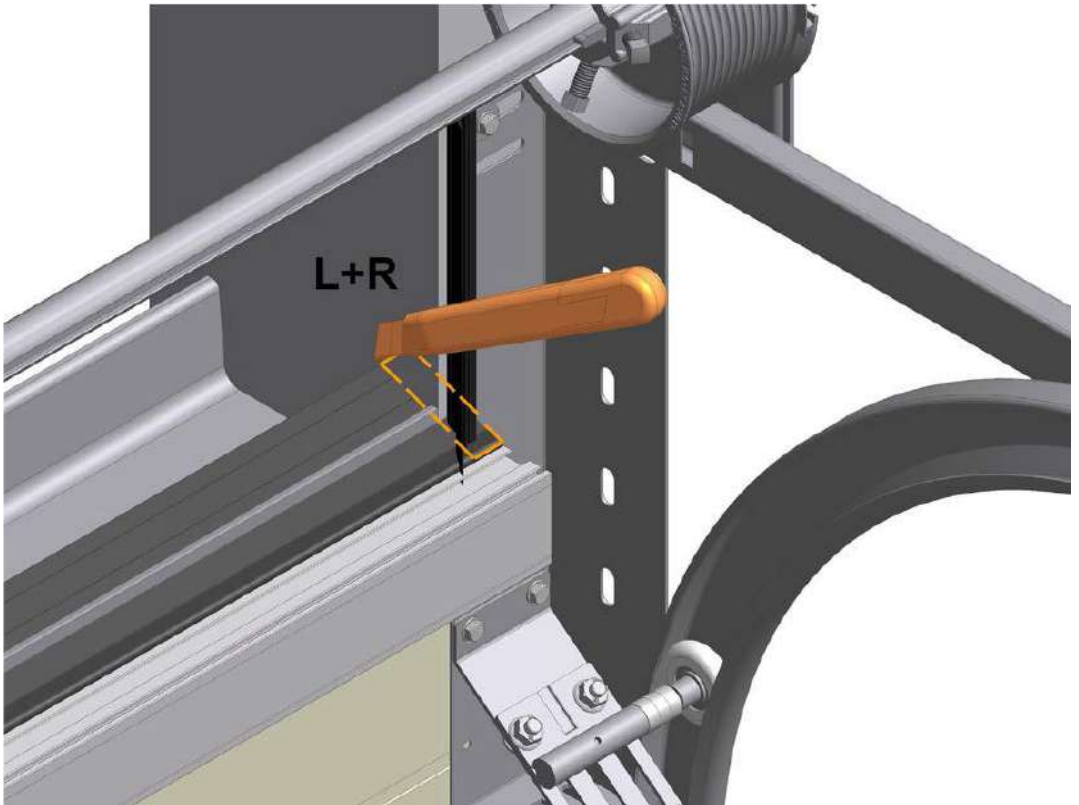
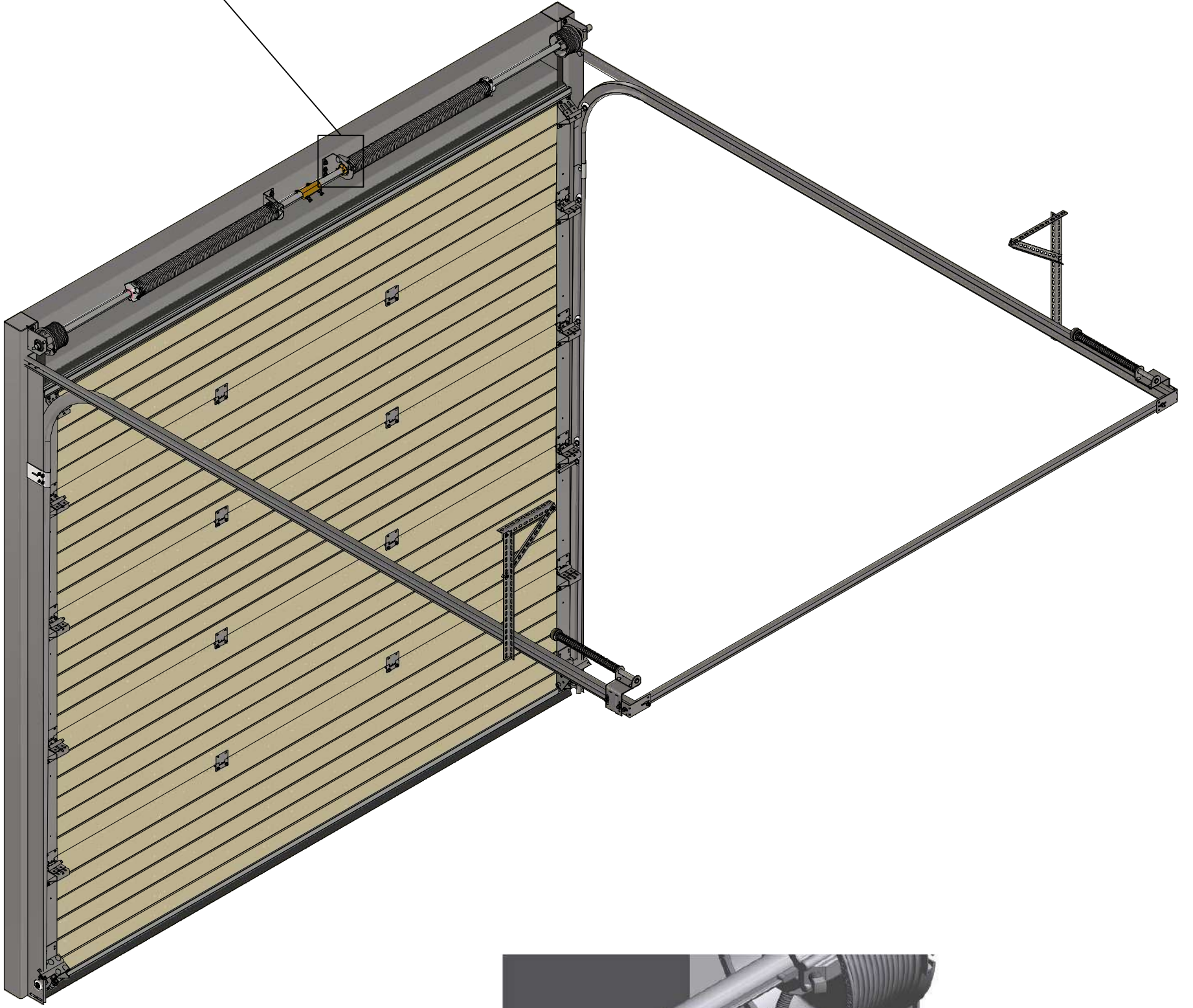

**Riga Door Systems**  
we open the world

Malas, Vetras, Marupe LV-2167, Riga district, Latvia; web: [www.rigadoors.lv](http://www.rigadoors.lv)

Designed by	VPA	Sheet Format	A3	Date	2023-12-08	Installation manual. RS 350		
						RDS 1000	Rev. 2	Sheet 36 / 38

# Option

BOTTICELLI SMART BT A

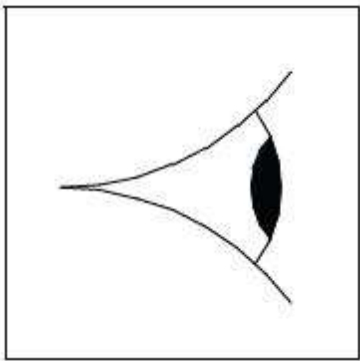

# Option

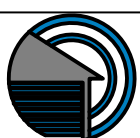
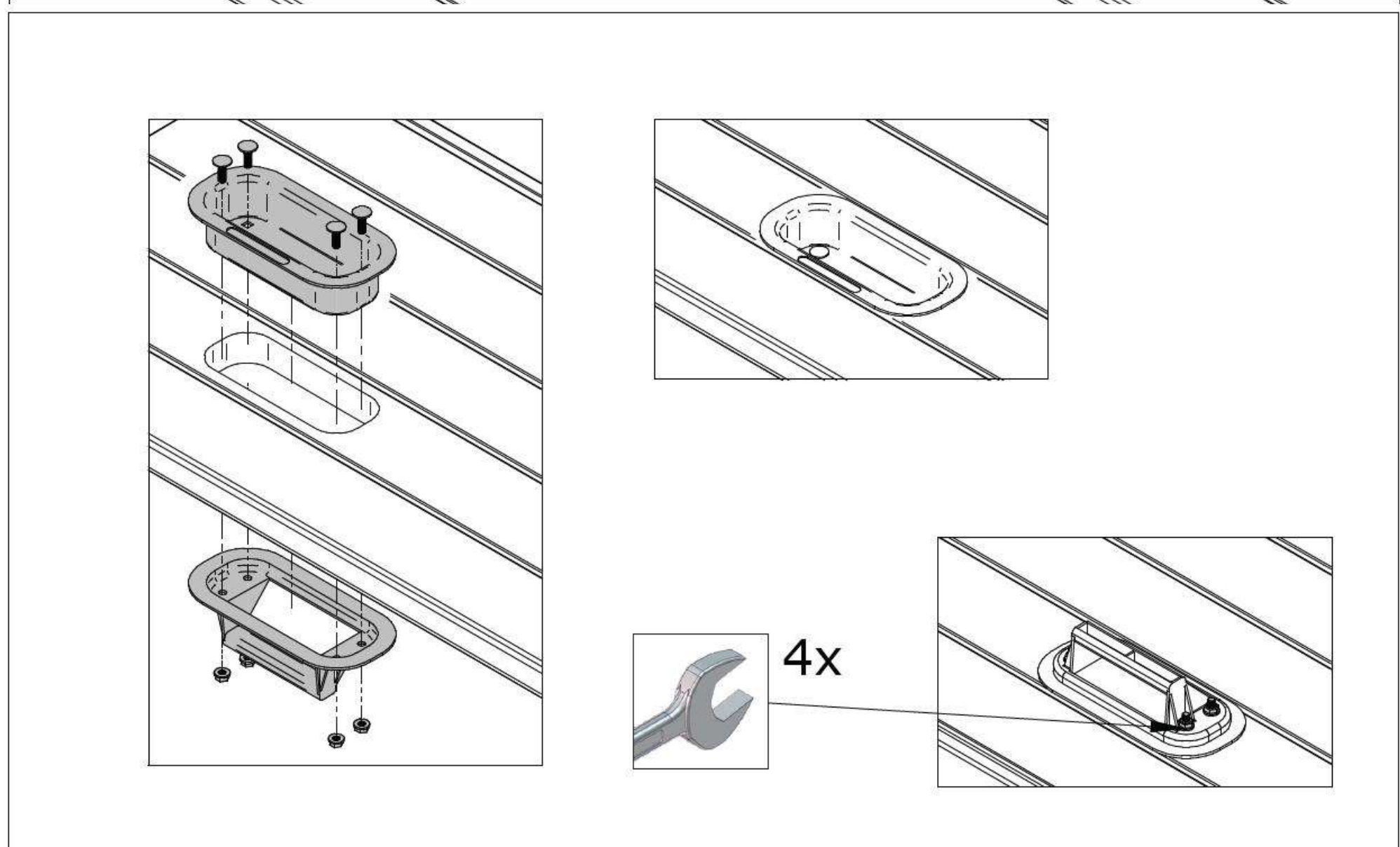
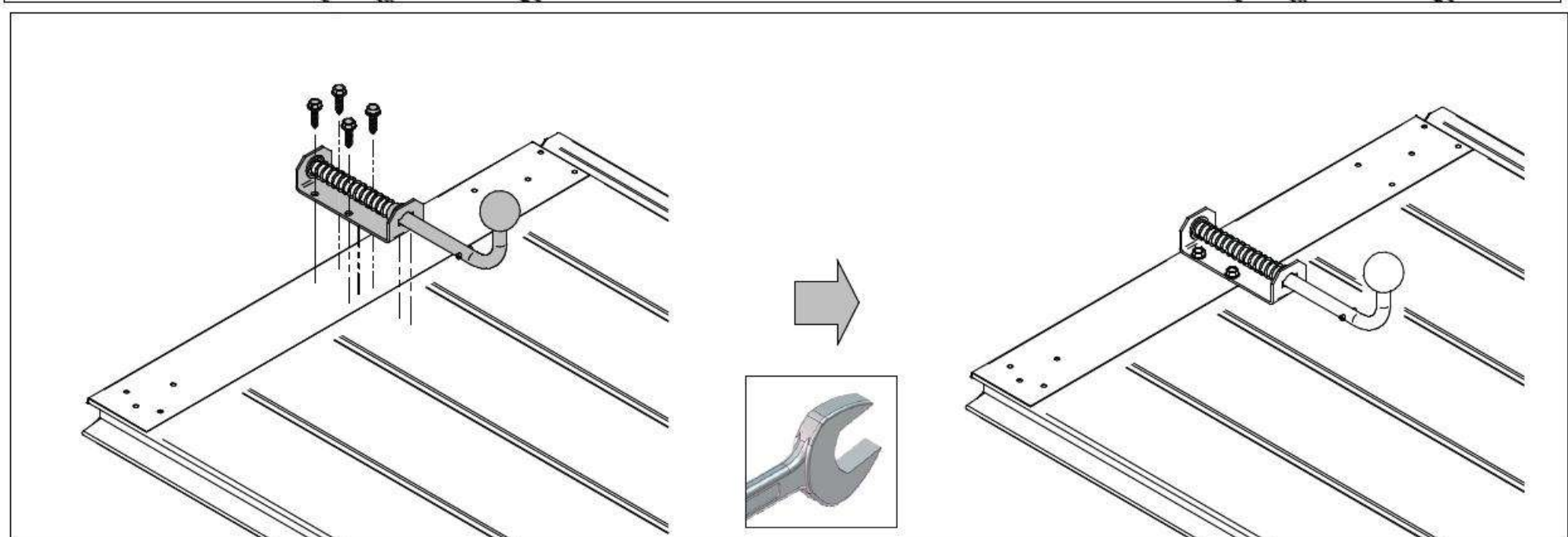
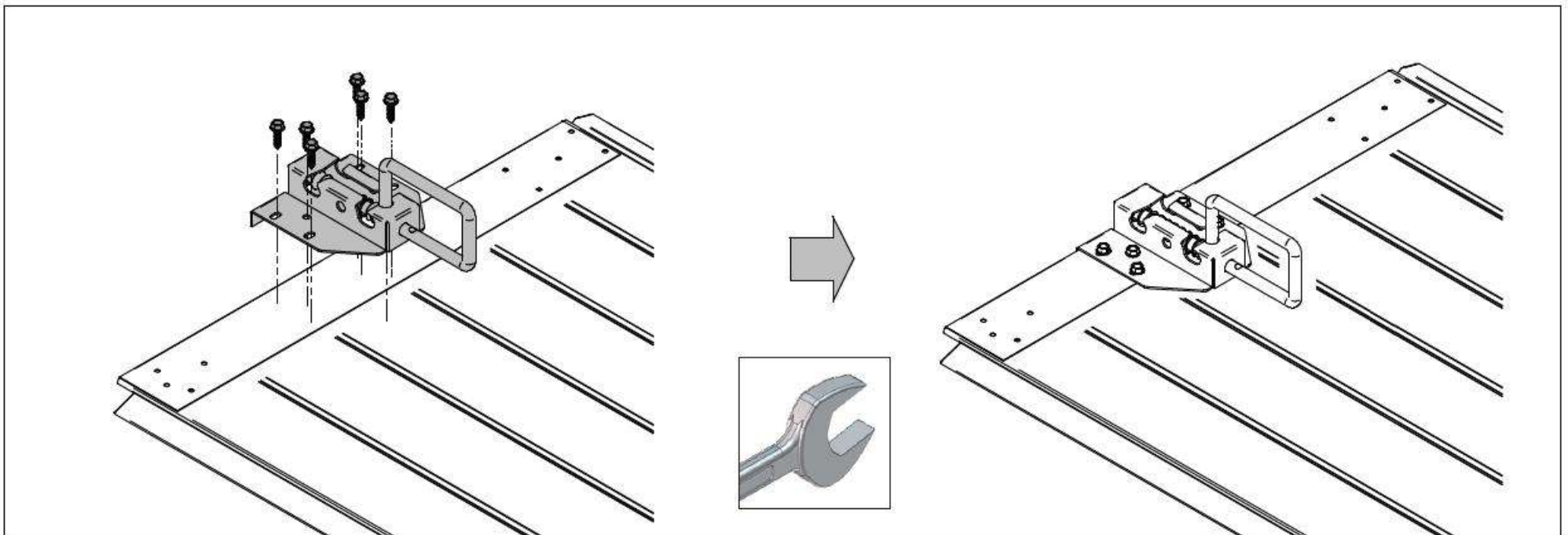

## First use

The First use of the Residential door System has to be carried out by the installer. After that the ALL users need to be instructed.

## Handover

Handover the following documents to the end user:

- This manual (assembly, maintenance and disassembly)
- Service logbook
- Declaration of Performance (DoP) (see door label)
- Declaration of Conformity (DoC), only in case of a Power operated door (see door label)

## Electric operator (optional)

Mount the operator according the supplier's manual.



### NOTE:

In case of power failure it should be possible to unlock the door using the emergency release from the operator. The door leaf may only in that case, be operated with a handle. Do not fit a pull cord, shoot bolt or lock to an electrically operated door, or the shootbolt or lock need to be equipped with a safety switch.

## Control unit settings

Settings to the control unit should be carried out in accordance with the operator manufacturers manual.

Please note that our hardware kits have been CE approved for use with the operators specified in our ITTr report. Should a different operator be chosen, then the installer must carry out a peak force analysis in accordance with EN-12445 and EN-12453.



## Disassembly

**Disassembly should be only carried out by an qualified residential door company / installer.**

The door should be disassembled in the reverse sequence to the assembly manual.



## Warnings

- Brackets and other components which are attached to Torsion Springs and Cables are under extreme tension.
- Tensioned springs carry a high tension; always be very careful, and make sure the tensioning bar are well maintained and use the right side of the bar (depends on used spring plug).
- When checking the residential door system, always disconnected the electrical main power supply and make sure that it is blocked against re-engaging without you knowing it.



## Procedure:

1. Release tension of the torsion springs!
  - a) Insert the 1st tensioning bar into the tensioning head
  - b) Keep a good grip on the 1st tensioning bar and carefully undo the bolts on the tensioning head and transfer the spring tension.
  - c) Now place the 2nd tensioning bar in the next hole of the spring plug and carefully release the spring. The spring is released from top to bottom.
  - d) Again, fit the 1st tensioning bar to the spring plug and release.
  - e) Repeat steps 3-4 until the spring is released.
  - f) Repeat steps 1-4 for the other spring (springs).
2. Remove the electrical operator, according the manual of the electrical operator
3. Release the bolts in the cable drums and remove the steel cables from the cable drums. Be careful for any remaining tension in the cables, check if the cables are slack!
4. Remove the power-unit. Do this by first removing the coupler and then carefully sliding both shaft halves out of the bearing plates. Be aware that components may slide along the shaft!
5. Remove the panel sections from top to bottom. Achieve this by removing the roller holders and centre hinges.
6. Remove the horizontal trackset
7. Remove the vertical trackset

## Disposal

All parts of this Residential Door System can be easily disposed of.  
Please consult your local authorities on this matter.



## Maintenance

In accordance with EU standards, Residential door systems should be maintained and checked regularly, from the first time of use, based on the indicated service by the installer. Maintenance needs to be recorded written. **Maintenance should be only carried out by an qualified residential door company / installer.**

## Warnings

- Brackets and other components which are attached to Torsion Springs and Cables are under extreme tension.
- Tensioned springs carry a high tension; always be very careful, and make sure the tensioning bar are well maintained and use the right side of the bar (depends on used spring plug).
- When checking the residential door system, always disconnect the electrical main power supply and make sure that it is blocked against re-engaging without you knowing it.

## Directly after installation (By Installer):

1. Lubricate the running part of the tracks (advice: PTFE)
2. Lubricate bearings and the shaft of the rollers (advice: PTFE)
3. Lubricate pins of the hinges from intermediate- and side-hinges (advice: PTFE)
4. Lubricate the bearing of the shaft (advice: PTFE)
5. Lubricate sealing rubbers (advice: special rubber grease or vasaline)

## After 3 months (By Installer):

- Check balancing system / Re-tensioning springs (relaxation springs)
- Complete visual inspection

### **Every 6 months (By User):**

- Check side seals, Top seal and Bottom Seal on damage or wear and tear
- Lubricate the running part of the tracks (advice: PTFE)
- Lubricate bearings and the shaft of the rollers (advice: PTFE)
- Lubricate pins of the hinges from intermediate- and side-hinges (advice: PTFE spray)
- Lubricate sealing rubbers (advice: special rubber grease or vasaline)
- Clean the panels (advice: shampoo for car cleaning with water), do not use aggressive detergents
- Wax the panels (advice: car wax)
- Remove dirt from the door and surroundings

### **Every 12 months or every 7500 door cycles (By Installer):**

- Check the cables and the end connections from the cable on damages or wear and tear
- Check the cable connection points on bottom bracket or cable break device and Cable drum
- Check the spring break devices in accordance with separate manual
  1. Check the position of the ratched wheel
  2. Check the function of the catcher
  3. Check the bolt and screws connection of the SBD
- Check the Cable Brack Device in accordance with the seperate manual
  1. Check the function of the Cable Break Device
  2. Check position of the knife of the Cable Break Device
  3. Check the position of the hinge pin
- Check the balance of the door and adjust if needed / check the manual operation
- Check the hinges on breaking and wear and tear
- Check the Pulley system (if present) for damages or wear and tear
- Check or test the fixations of the springs to the spring plugs
- Check the rollers or damages or wear and tear and free moving space
- Check the closing forces of the main closing edge (Only if Electrical Operation an Not Deadman function)
- Check the suspension from the horizontal track to the ceiling
  1. Check the suspension profiles on breaking or damages
  2. Check the bolt and nut connection
- Check side seals, Top seal and Bottom Seal on damage or wear and tear
- Check the panels on damage, wear and tear
- Lubricate torsion springs, bearings of rollers, running parts of the track and bearing on the shaft

### **Every 24 months or every 15000 door cycles (By Installer):**

- Check the cables and the end connections from the cable on damages or wear and tear
- Check the cable connection points on bottom bracket or cable break device and Cable drum
- Check the spring break devices in accordance with separate manual
  1. Check the position of the ratched wheel
  2. Check the function of the catcher
  3. Check the bolt and screws connection of the SBD
- Check the Cable Brack Device in accordance with the seperate manual
  1. Check the function of the Cable Break Device
  2. Check position of the knife of the Cable Break Device
  3. Check the position of the hinge pin
- Check the balance of the door and adjust if needed / check the manual operation
- Check the hinges on breaking and wear and tear
- Check the Pulley system (if present) for damages or wear and tear
- Check or test the fixations of the springs to the spring plugs
- Check the rollers or damages or wear and tear and free moving space
- Check the closing forces of the main closing edge (Only if Electrical Operation an Not Deadman function)
- Check the suspension from the horizontal track to the ceiling
  1. Check the suspension profiles on breaking or damages
  2. Check the bolt and nut connection

- Check the shaft on damages and wear and tear
- Check the connection of the trackset
- Check and re-fix the bolt of the coupler
- Check side seals, Top seal and Bottom Seal on damage or wear and tear
- Check the panels on damage, wear and tear
- Lubricate torsion springs, bearings of rollers, running parts of the track and bearing on the shaft

## **Replacements of Parts**

Only use Original Riga Door Systems Ltd spare parts!

Maintenance should be only carried out by a qualified residential door company / installer.

### **After Spring Break:**

1. Replace the springs
2. Check Spring Break Device on damages and replace if necessary
3. Check the shaft on damages and replace if necessary

### **After Cable Break:**

1. Replace cable with connection
2. Replace the complete Cable Break Device if necessary
3. Check tracks and service or replace the tracks



