

The top of the gate

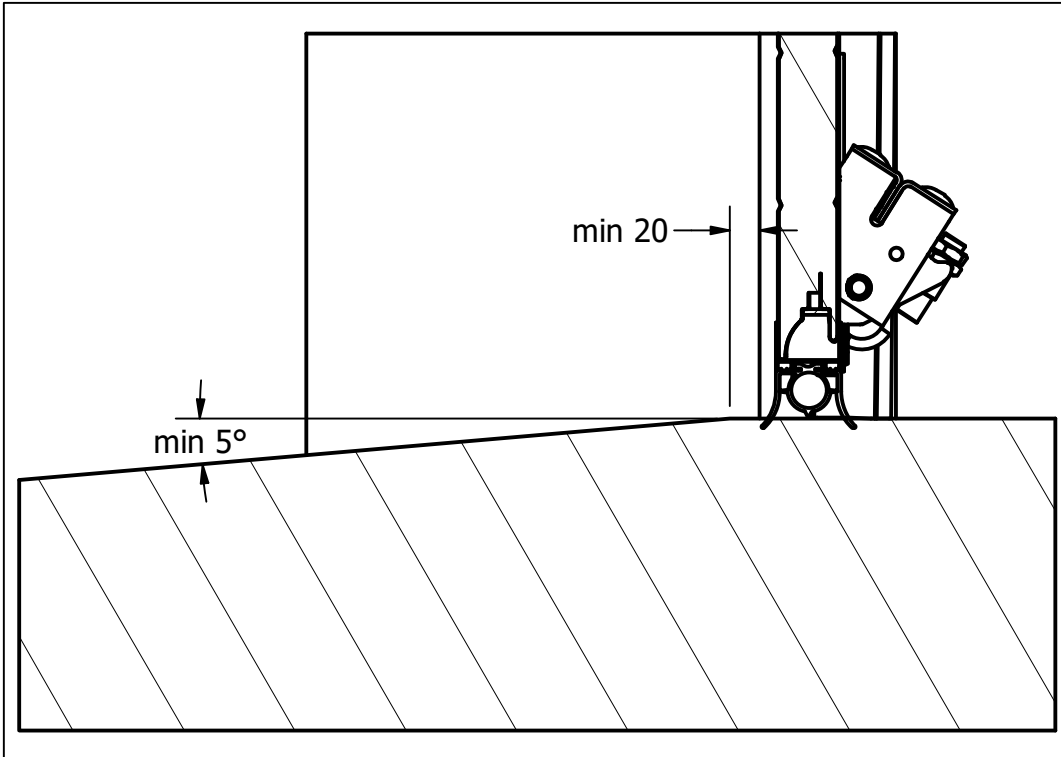

The bottom of the gate

X=250, H<=4002; S<= 20 m<sup>2</sup>  
 X=270, H<=5000; S<= 25 m<sup>2</sup>  
 W>5000;H>5000 contact the manufacturer ⚠  
 B- Free opening:

H-120mm- Opening with motor or chain hoist

H-200mm- Opening with arm

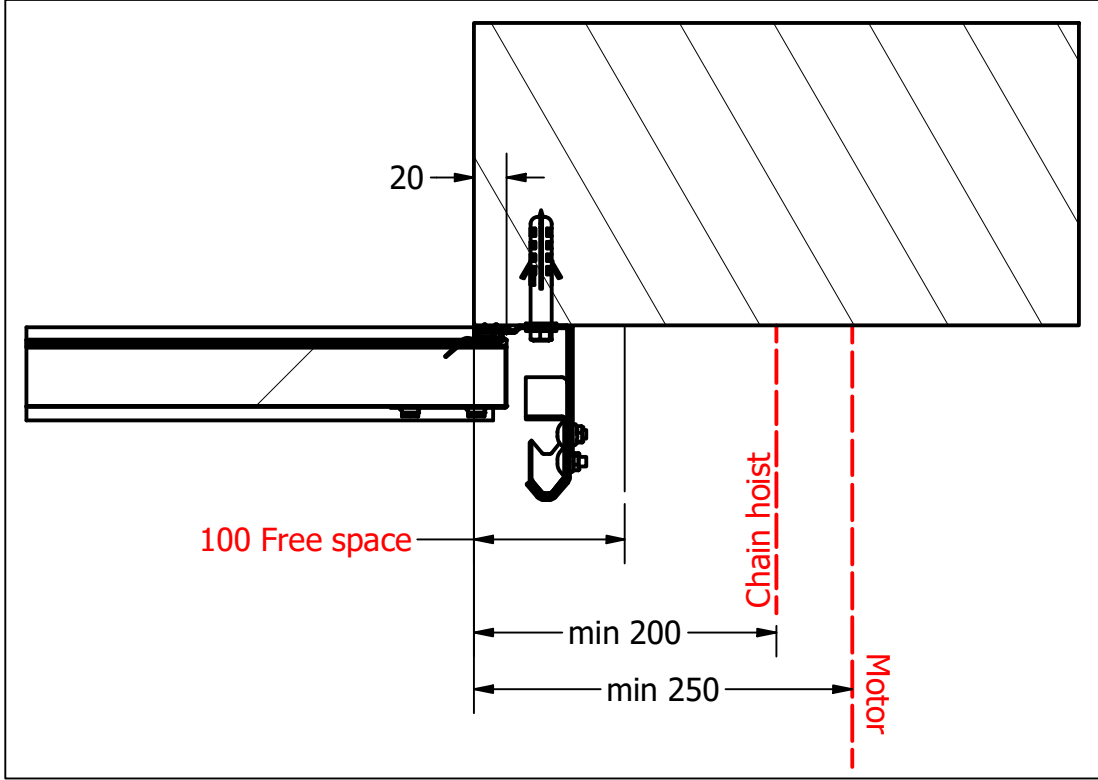
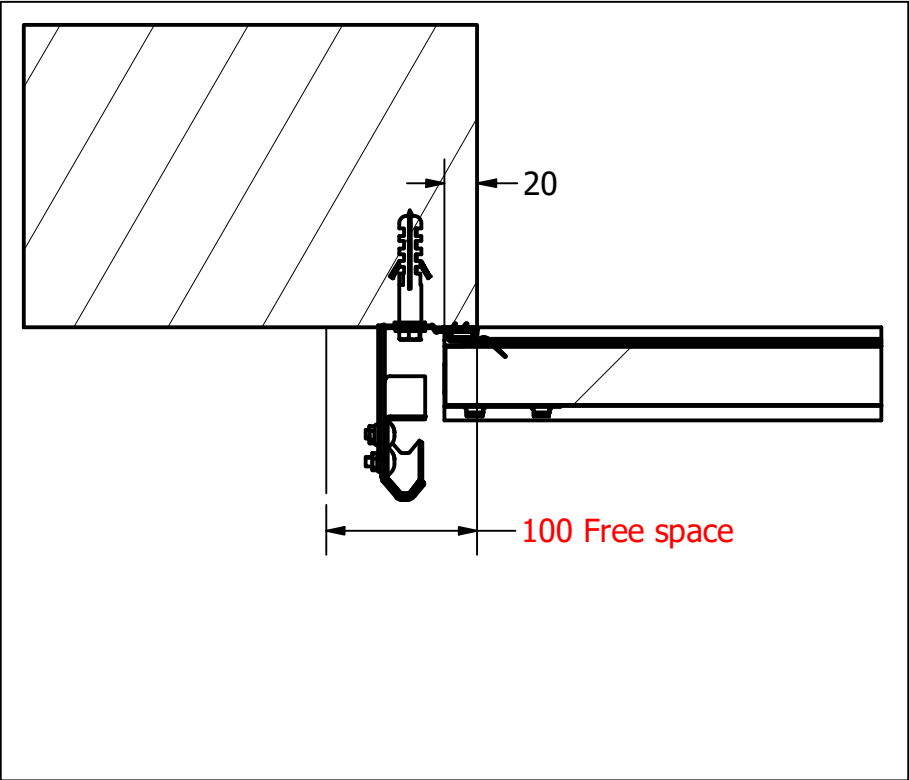

Sealing at the column

⚠ For gates without motor and H>=3m chainhoist must be mounted !