

1

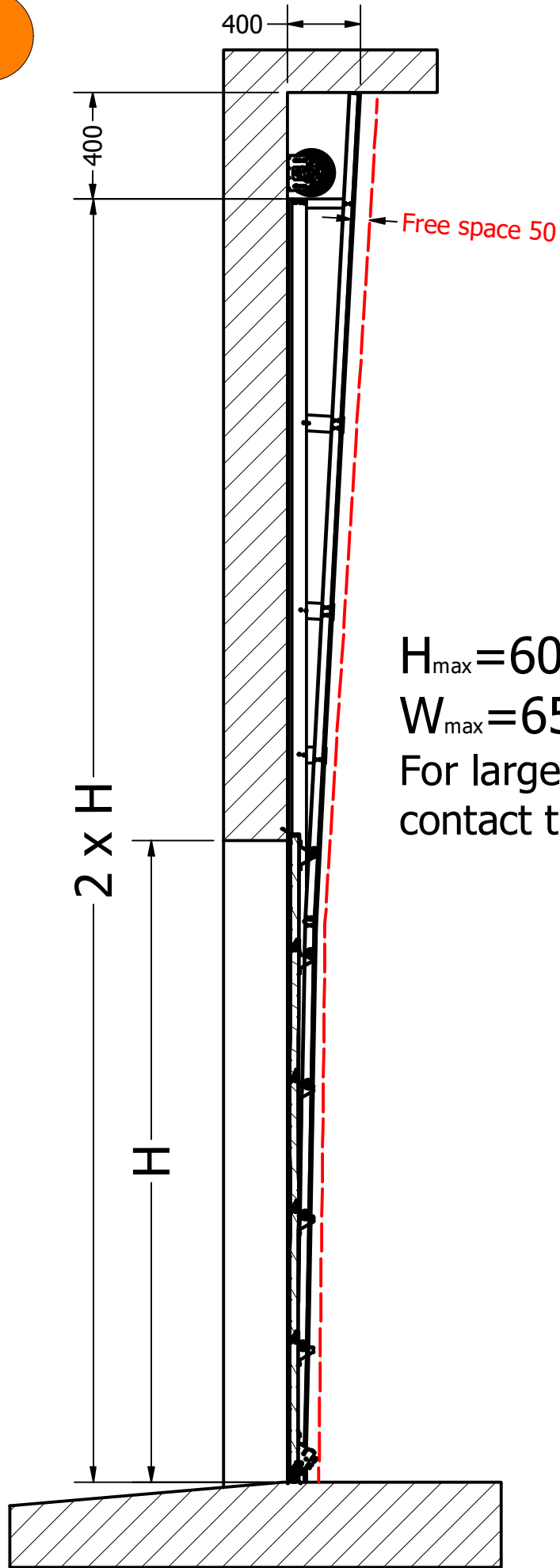

$H_{max} = 6000$

$W_{max} = 6500$

For larger sizes,
contact the manufacturer



The top of the gate

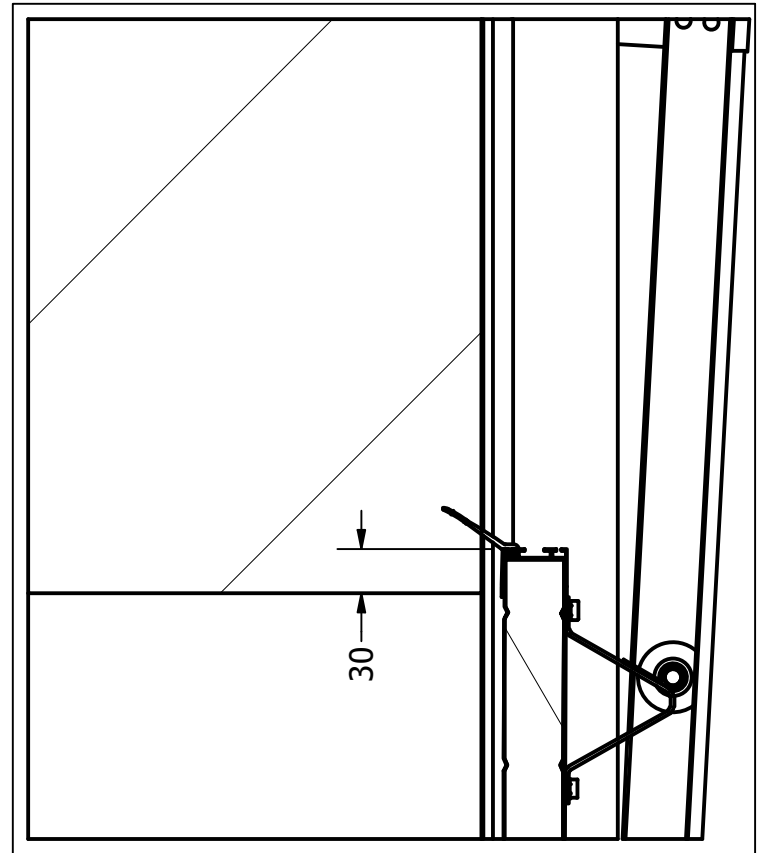

The bottom of the gate

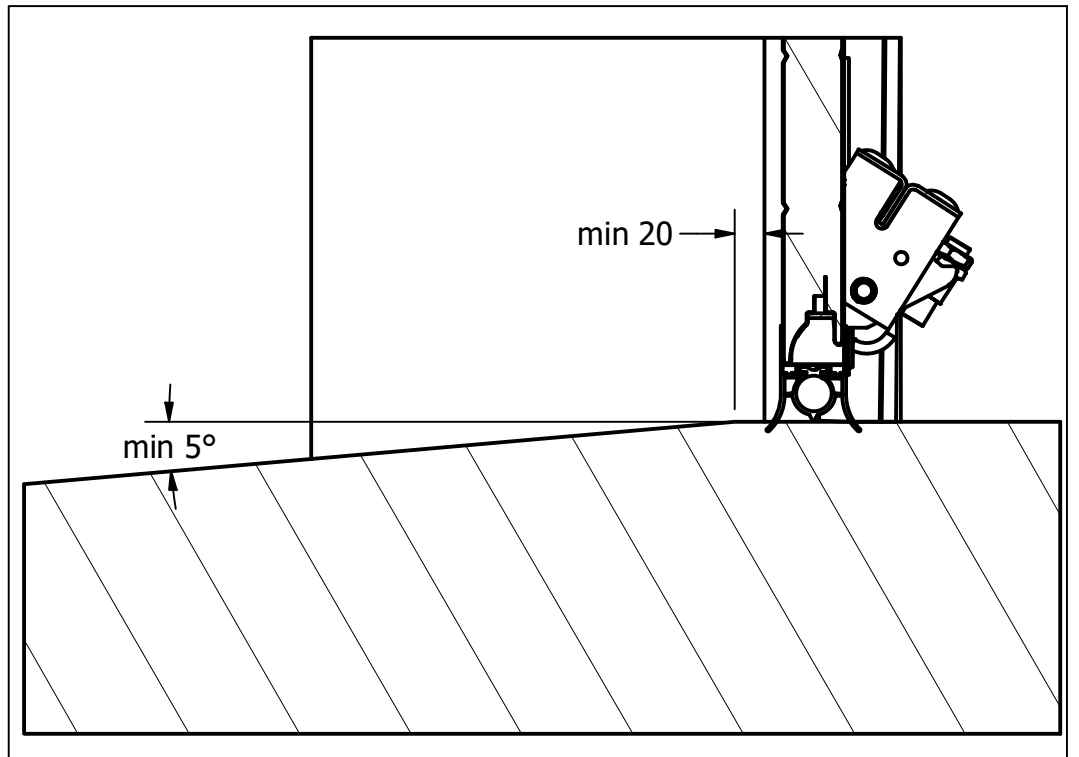

Sealing at the column

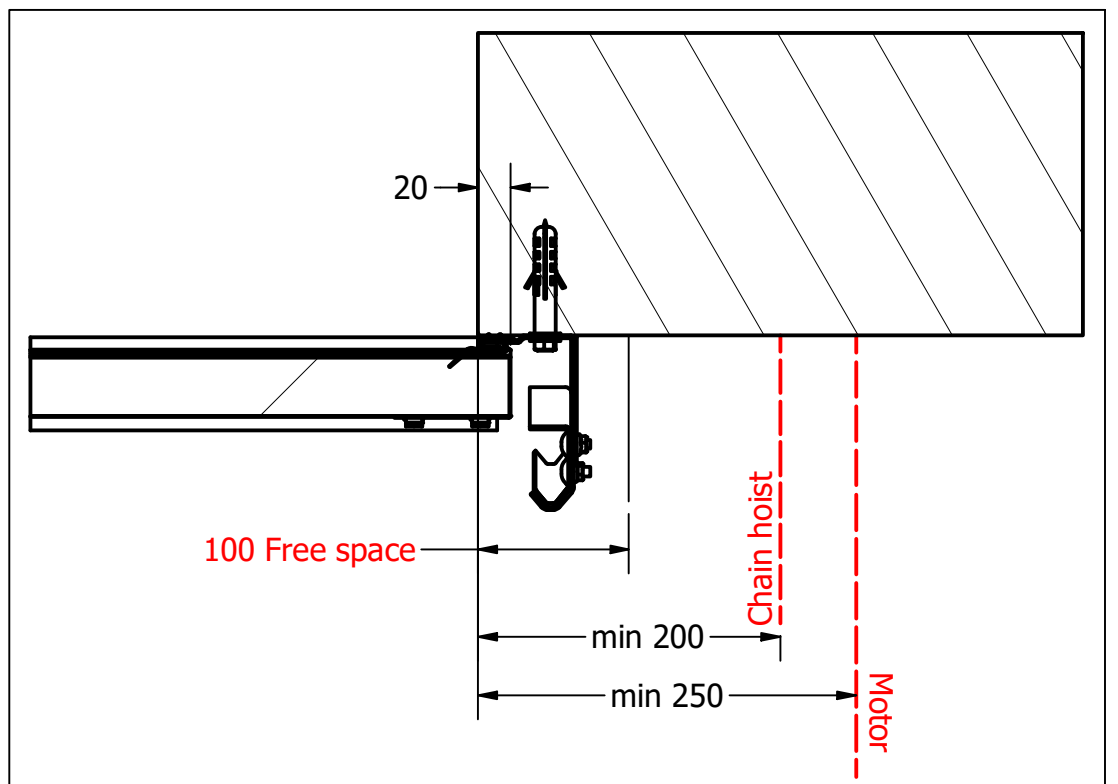
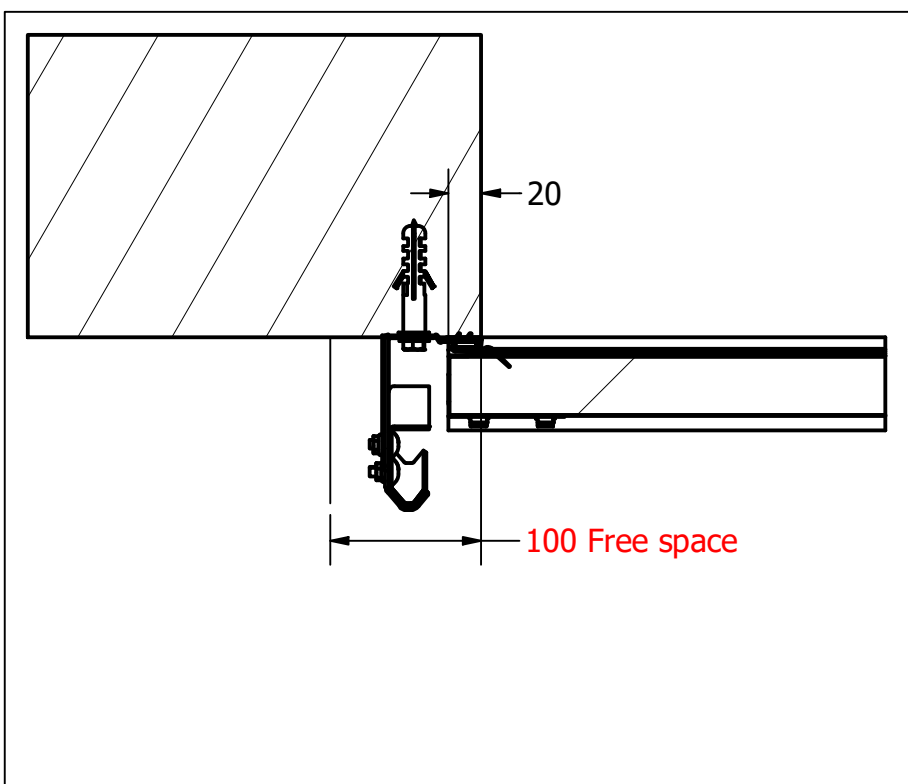

⚠ For gates without motor and $H \geq 3m$ chainhoist must be mounted!



Riga Door Systems
we open the world

Malas, Vetras, Marupe LV-2167, Riga district, Latvia; web: www.rigadoors.lv

Designed by

VPA

Sheet Format

A3

Date

2024-04-26

VL_Vertical lift

Data sheet

Industrial sectional gates RDS 1000

Rev.

0

Sheet

1 / 1